

Improved Accuracy of Damage Index Evaluation in Concrete Structures by Simultaneous Hardware Triggering

Francesco Lamonaca¹⁾, Antonio Carrozzini²⁾, Domenico Grimaldi¹⁾, Renato Sante Olivito²⁾

1) *Department of Computer Science, Modelling, Electronic and System Science, University of Calabria, 87036 Rende – CS, Italy*
(✉grimaldi@deis.unical.it)

2) *Department of Civil Engineering, University of Calabria, 87036 Rende – CS, Italy*

Abstract

Non-invasive damage monitoring of concrete structures by means of Acoustic Emission (AE) requires multi-transducers, multi-channel acquisition, high sampling frequency and long observation time. Owing to its propagation in concrete, the signal from AE reduces its amplitude during the propagation, and, consequently, some events can be lost due to lower signal intensity than the trigger level set on one sensor only. The innovative proposal discussed in the paper consists in the introduction of a Flat Amplifier and Trigger generator block (FAT) in order to generate a logical trigger when the AE is detected by any transducer. Experimental tests confirm the effectiveness of the FAT to acquire all the AE events and to increase the evaluation accuracy of damage indexes.

Keywords: acoustic emission, multi-triggering, non-destructive techniques.

© 2014 Polish Academy of Sciences. All rights reserved

1. Introduction

Nondestructive techniques are widely used for the characterization of material defects [1], geometrical [2-4] and dynamical [5, 6] properties of systems. One interesting application of nondestructive techniques is the monitoring of civil and industrial structures. In this field, Acoustic Emission Testing (AET) can be performed *in-situ* and during the in-service loading of the structure, making it suitable for long-term or continuous monitoring of structures [7]. The AET detects the transient elastic waves generated by the rapid release of energy from localized sources within concrete. These waves propagate through the concrete and piezoelectric transducers can detect their arrival at the surfaces.

In order to investigate the relationship between the Acoustic Emission (AE) characteristics and the applied load [8, 9] in concrete material structures, continuous monitoring with the sampling frequency in the order of MHz [10], and long observation time interval are required [11].

The accuracy of the damage evaluation depends on the accurate evaluation of the AE events. In order to reduce the number of events lost due to the attenuation of the AE signal during the propagation in the concrete, a valid solution is the use of more than one transducer in order to increase the monitored area, as shown in Fig. 1.

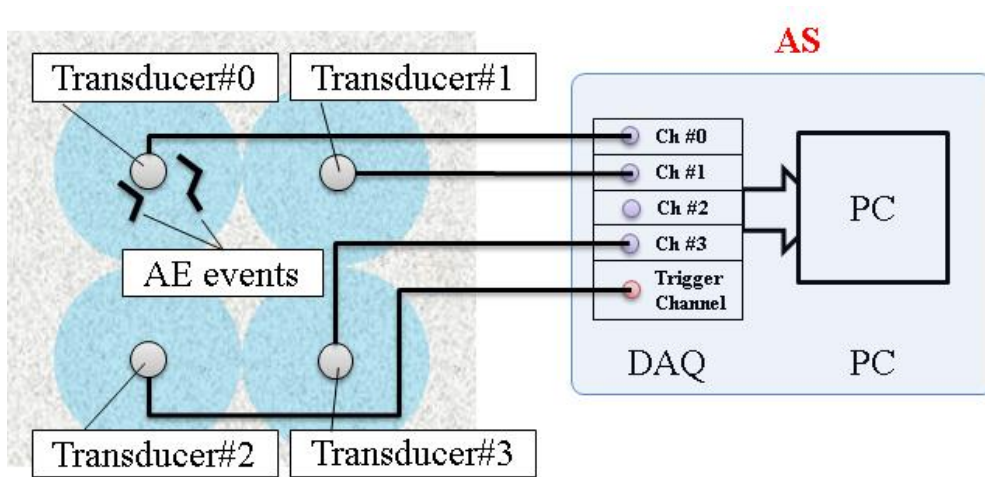

Fig. 1. Multi-transducers and coverage area to detect AE events. Transducer#2 furnishes the trigger to the acquisition system (AS).

Owing to the problems of storing a large amount of digitized data, and of acquiring only the AE events [12], the triggered acquisition modality is used, i.e. only the signals overcoming the noise floor are stored.

Nevertheless, in accordance with the internal structure of the concrete and the unpredictable damage modality, some AE events can occur far away from the transducer selected as trigger, i.e. transducer#3 in Fig. 1. According to the signal propagation attenuation, some AE events can reach the coverage area with intensity lower than the trigger level. Therefore, this AE event is lost, and the evaluation of the damage index would be degraded by such missing information.

In this case, the traditional Acquisition System (AS) is not suitable for the purpose. Indeed, although AS allows the simultaneous acquisition of more than one input signal, it permits the trigger condition to be set up only on one input channel: the Trigger Input [13].

In order to acquire all the AE events, in [14] it is proposed to add the Flat Amplifier and Trigger generator block (FAT) to the traditional AS architecture. The FAT is designed to generate the trigger when one or more signals among those detected by the transducers overcome the noise floor. It effectively permits increasing the evaluation accuracy of damage indexes.

This paper highlights the effectiveness of the FAT to improve the accuracy of the damage evaluation by performing experimental tests and comparing the trend of two damage indexes in the case where the AEs are acquired by the traditional AS or by the AS with the FAT.

The first index taken into consideration is the local damage evaluation index based on the cumulated hits of the AEs. The second index taken into consideration is the aggregate damage index used in [14]. Both the indexes show the effect of the FAT on the data acquired on each channel and highlight the advantages introduced by the FAT with respect to the traditional AS. The improvement is also justified by the fact that the damage indexes are based on the history of the AE events, and the FAT permits the number of acquired AEs to be increased.

The paper is organized as follows: the AS architecture by using the FAT is described for the sake of completeness; then the experimental set-up is discussed; next the results of the experimental tests are shown; finally, conclusions are drawn.

2. Acquisition system architecture by using FAT

The FAT block is connected in hardware modality to all the channels/transducers. No matter which of them receives the AE event signals greater than the threshold, the trigger signal is sent to the AS. Therefore, all the signals incoming from all the transducers are acquired and stored.

Fig. 2 shows the multi-triggering architecture pointed out by the FAT block.

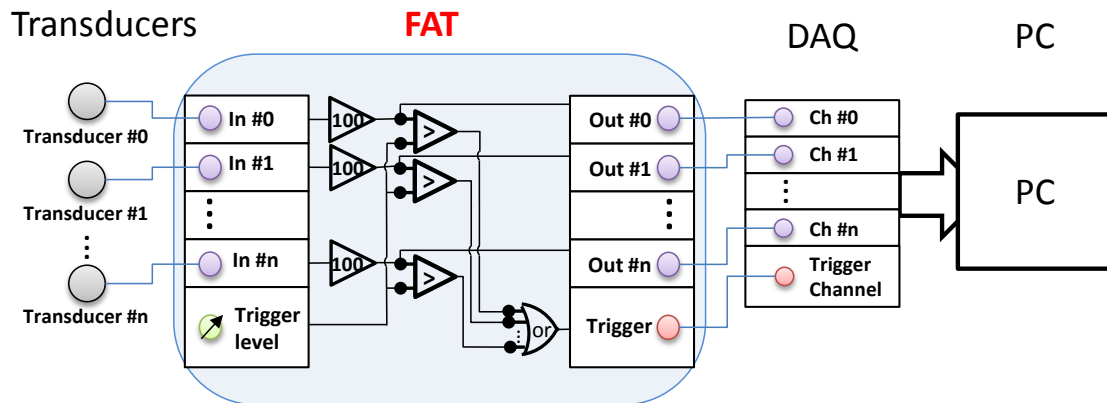

Fig. 2. Block scheme of the acquisition system architecture by using FAT.

The output voltage of each transducer is connected to the input of the FAT and amplified with a flat transfer characteristic in the range from 9 kHz to 300 kHz [10, 12]. Successively, each amplified voltage signal is compared with the threshold level set by the operator according to the noise floor. The operator can check the noise floor level by setting the continuous acquisition on the AS and performing the pre-acquisition of the signals on the four channels. The result of each comparison is the input to the OR logical port, connected to the digital trigger of the AS. The digital output of the OR is high when one or more signals overcome the trigger level. Only when the trigger occurs the acquired data are transferred to the PC to be stored and processed.

It is worth remarking that the number of memory locations set as pre-trigger, M , is established on the basis of the delay introduced by the FAT in order to not lose part of the signal. Such delay is determined by (i) the propagation delay introduced by the comparator, (ii) the OR, and (iii) the trigger level set by the operator. For this reason M can be experimentally established during the preliminary test phase.

For each input channel, the amplifier section is made up of the cascade of two Burr-Brown INA 111 [15]. It allows amplification of $10\% \pm 0.01\%$ in the range from 1 kHz to 1000 kHz. The trigger section is made up of two comparators ADCMP563BRQZ [16] and OR logical port MC10EL01/D [17]. These components are suitable for the applications because they introduce a propagation delay equal to 530 ps for the comparators, and 230 ps for the OR. Therefore, the overall delay between the generated digital trigger and the amplified signal at the input of the AS is less than 1ns. Since the AE signal is in the order of hundreds of kHz and, consequently, the sampling frequency is in the order of MHz, the delay introduced by the FAT block can be considered negligible.

Alternatively, a solution based on FPGA would be pointed out to perform the multi-triggering by continuous evaluation of each acquired sample on each channel. This solution has the following inconvenience: (i) expensive high-speed FPGA chips [18], (ii) limited speed of the FPGA chip, and (iii) being limited on board memory.

3. Experimental set-up

Experimental tests were conducted on a concrete cubic specimen with dimensions $15\text{ cm} \times 15\text{ cm} \times 15\text{ cm}$, without any steel reinforcement, cured 28 days according to UNI 12390-2, 2003 standard code [19]. The specimen was monitored during the experimental tests by means of a multi-channel device equipped with acoustic emission piezoelectric transducers. The position of the transducers should take into account the symmetry conditions characterizing the geometry of the tested specimen. Four AE piezoelectric transducers are placed on four sides of the specimen. Fig. 3 shows the transducer positions and the tested point indication. Accurate preparation of the surface of the structure on which the transducers is applied is a fundamental aspect for correct test execution. The AE transducers are firmly fixed, and silicon vacuum grease is applied between each transducer and the specimen for better signal transfer. Concerning the transducers, their selection depends on the application, type of flaws to be revealed, noise characteristics and other factors [20]. Basically there are two types of AE transducers: broad-band and resonant type. Broad-band transducers have low sensitivity but they are effective in broad frequency regions and may record additional background noise. Resonant transducers are only effective at higher resonant frequencies and normally operate above the background noise. Most researchers recommend the use of resonant transducers, as they are highly sensitive to typical AE sources [21]. A solution is to use a broad-band sensor for initial tests in a sample specimen, and using this frequency response to select a resonant transducer [22].

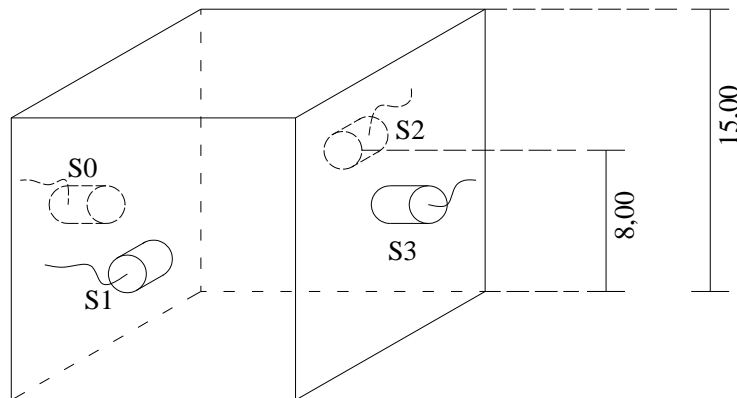

Fig. 3. 3D position of the piezoelectric transducers on a concrete specimen during the test.

As suggested in [23]-[26], the AE transducers are R15 α Sensor, characterized by operating frequency in the range from 50 kHz to 200 kHz, peak sensitivity 69 V/(m/s), resonant frequency 150 kHz, directivity ± 1.5 dB. The transducers are connected to the FAT and then to the AS made up of a NI 6110 DAQ board [13]. The sampling frequency is set equal to 5MS/s. The software is run in environmental LabView.

The whole monitoring system, including the FAT block and AS, is checked by generating AE events. In this way, the correct answer to the system and the repeatability of the event is assessed. In particular, the Hsu-Nielsen source is used to generate the AE event, by breaking the 0.3 mm pencil lead (hardness 2H), according to the EN 13477-2 standard code [27].

Once the checking of both the FAT block and AS is carried out, experimental tests are conducted by generating AE events by means of the controlled uni-axial compression of the specimen. The compression tests are carried out after the curing phase and according to [27]. The tests are conducted by means of a hydraulic press with a closed loop governing system

with a capacity of 3000 kN and accuracy class 0.5%, connected to the AS to record the load-displacement diagram. A constant displacement rate is adopted equal to 0.1 mm/min and load is conferred slowly until failure.

The experimental tests are executed by acquiring the data during a compression test choosing as trigger signal one channel of the AS or, alternatively, the trigger output of the FAT.

Owing to the heterogeneity of the concrete material and the imperfections of the sample (bubbles, defects) the comparison of the effectiveness with which the damage index is evaluated by using the two acquisition systems must be performed by placing the transducers of the two acquisition systems in the same place at the same time [28]. Since this approach is not possible in practice, the data are acquired by using the FAT and the case of the traditional AS is evaluated by discarding the data obtained when the ChX selected as input does not detect the trigger. In particular, the following procedure is used to evaluate the data in case the trigger is defined on the input channel Ch#X of the AS with level TL:

- read data file,
- for each event acquired on channel ChX, save in the vector T only the time stamp of the event in which the AE signal overcame TL,
- build the new data file by extracting from the original data only the event time stamped with values belonging to T.

The analysis of the acquired data is performed according to the processing procedure described in [22, 23]. In particular the features of the AE signal (Fig. 4) are used [31] to evaluate the two indexes: cumulated hits, and damage index (including the Historic index and the Severity index [32]).

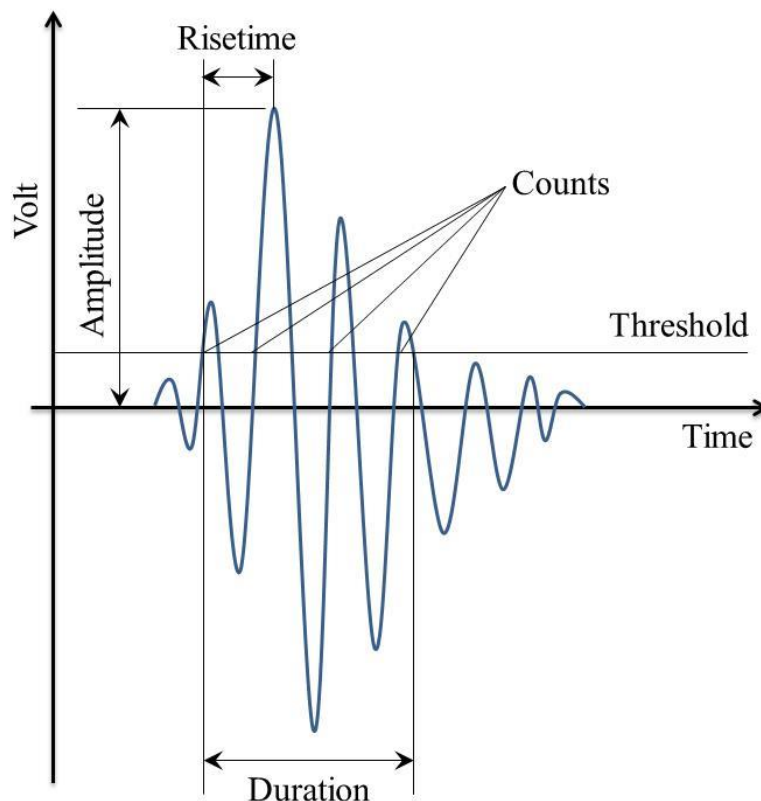

Fig. 4. Features of the AE signal.

Owing to the reduced dimension of the specimen, the number of acquired event changes according to the input channel chosen as trigger.

4. Experimental assessment of the effect of the FAT on each channel of AS

In order to assess the operating modality of the actual realization of the FAT, the number of AE hits and events was detected inside concrete specimens subjected to compression tests.

Fig. 5 compares the cumulated hit curves evaluated by using the FAT (bold line) and the cumulated hit curves evaluated by setting the trigger on Ch#0, Ch#1, Ch#2, and Ch#3 of the traditional AS, respectively. From the analysis of the experimental results, the advantages of the FAT system were noticed. From the comparison between cumulated hit curves obtained by using the FAT and the traditional AS, relative to the same channel, a great loss of useful data especially in the ultimate phase of the test is evident. In particular, without the FAT the number of hits is noticeably decreased. This phenomenon is particularly evident for concrete specimens due to the fact that the material is non-homogenous, there can be voids or defects inside and the AE acquisitions are affected by these physical properties of the specimen. These results confirm that the FAT allows an improvement of the acquired data accuracy, giving useful information about the stress level reached by the specimen subjected to the mechanical test.

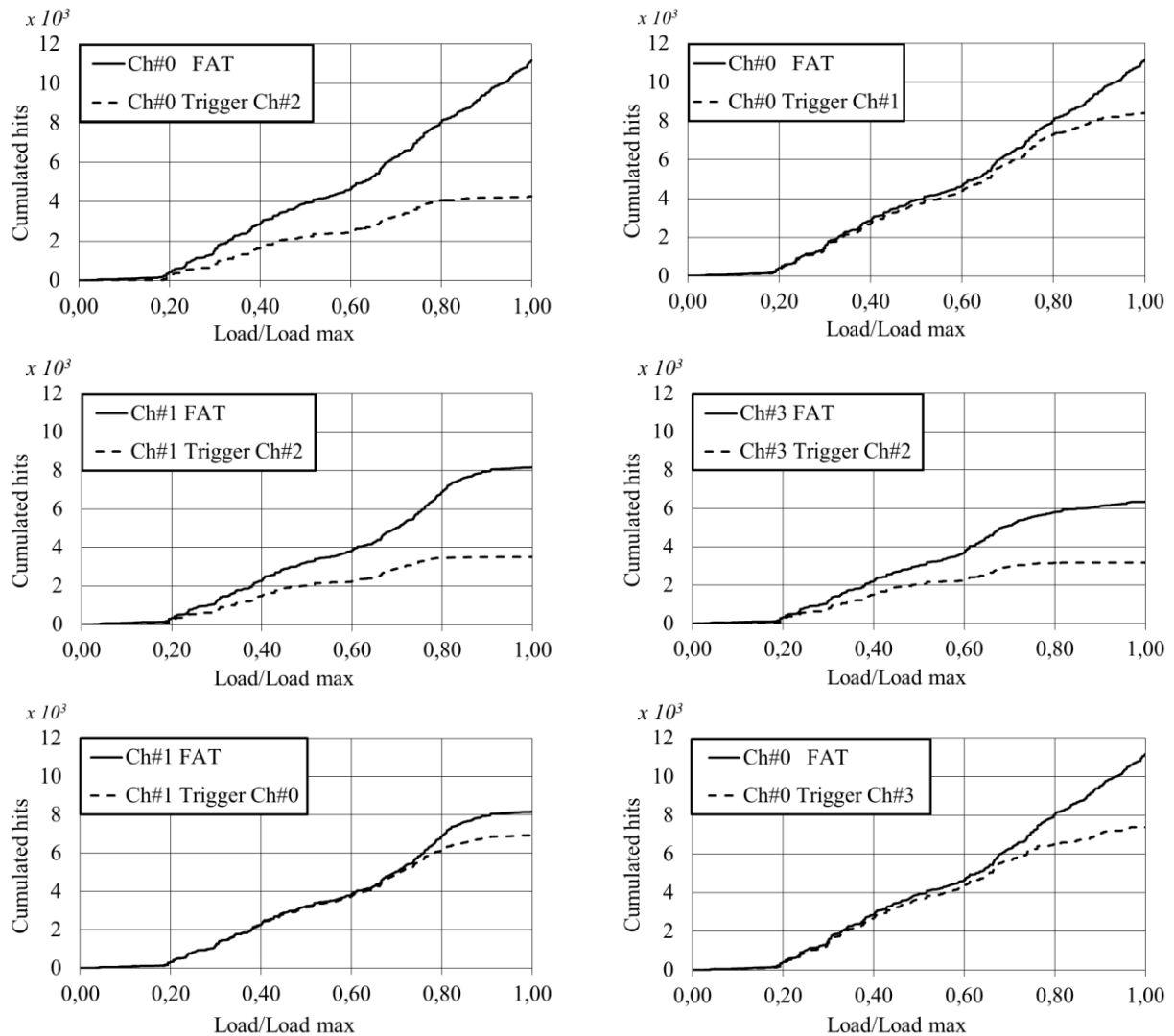

Fig. 5. Cumulated hits by using the FAT and the traditional AS.

5. Experimental assessment of the effect of the FAT on the damage index

In order to assess the effectiveness of the actual realization of the FAT to the correct evaluation of the damage of the concrete, the Historic and Severity indexes are evaluated:

Historic index [32], is the measure of the change in signal strength through the loading phase of the test:

$$H(I) = \frac{N}{N - K} \cdot \left(\frac{\sum_{i=K+1}^N S_{oi}}{\sum_{i=1}^N S_{oi}} \right), \tag{1}$$

where: N number of hits up to time t ; S_{oi} signal strength of the i -th hit; K empirically derived constant based on the material;

Severity index [33] is the average signal strength among the largest numerical values of the signal:

$$S_r = \frac{1}{J} \cdot \left(\sum_{m=1}^J S_{om} \right), \tag{2}$$

where: J empirically derived constant based on the material; S_{om} signal strength of the m -th hit, where the order of m is based on the magnitude of the signal strength.

Table 1. K and J values versus the number of hits N .

N	K	J
<50	0	0
$51 < N < 200$	$N-30$	50
$201 < N < 500$	$0.85 \cdot N$	50
$N > 501$	$N-75$	50

K and J values for concrete are related to N by the relations shown in Tab. 1 [22, 26].

These indices are evaluated from the signal strength data collected by each transducer. The Severity index and maximum value of the Historic index is plotted on an intensity chart, which may be divided into the zones of damage shown in Fig. 6 [29].

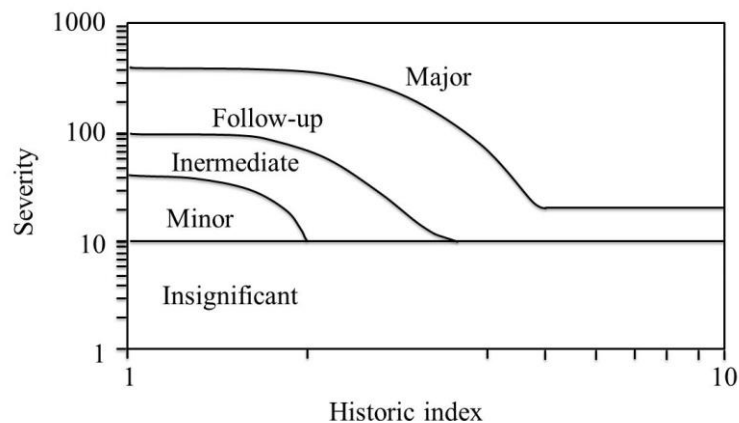

Fig. 6. Intensity chart for concrete material.

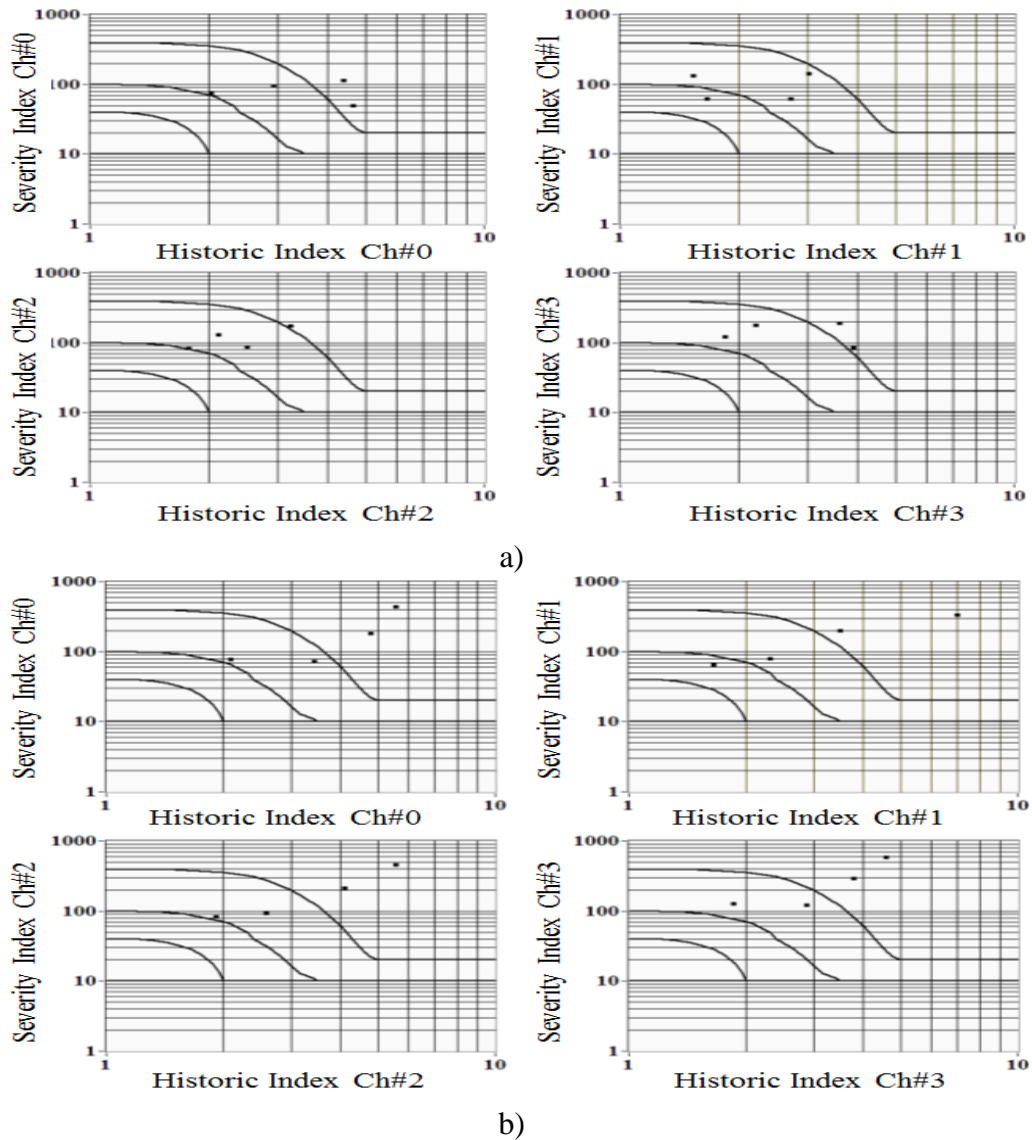

Fig. 7. Intensity plot up to 100% of damage in the case the trigger signal is generated by a) channel 2, and b) by the FAT.

The experimental tests confirm that the specimen damage can be correctly evaluated only by using the trigger signal furnished by the FAT. Otherwise, the loss of AE events due to the selection of a single input channel/transducer as trigger, can misinterpret the damage evaluation (see Fig. 7 a)).

The experimental test confirms the effectiveness of the proposed FAT to acquire all the AE events and then to increase the accuracy of the damage indexes.

6. Conclusions

The non-destructive monitoring of concrete structures based on AE events generated by the cracks requires: (i) high sampling frequency, (ii) continuous monitoring, (iii) long observation times, (iv) use of multiple transducers to monitor large surfaces. These requirements suggest the triggered acquisition modality to reduce the size of the acquired data.

In order to overcome the problem of the single channel selectable as trigger, we propose to add the Flat Amplifier and Trigger generator block (FAT) to the traditional acquisition system architecture.

The FAT is designed to generate the trigger when one or more signals among those detected by the transducers overcome the trigger level.

This solution permits overcoming the problem arising when some AE events can reach the coverage area of the transducer selected as trigger with intensity lower than the trigger level. This AE event is lost by the traditional acquisition system, and the evaluation of the damage index would be degraded by such missing information.

The effectiveness of the FAT to the correct evaluation of the damage of the concrete is experimentally investigated by taking into consideration: (i) the local evaluation index based on the cumulated hits of the AEs and (ii) the aggregate damage index including the Historic index and the Severity index. The experiments highlight the dependence of the damage indexes on the trigger channel when the FAT is not used. Vice versa, both the indexes highlight the advantages introduced by the FAT with respect to the traditional AS in the improvement of the accuracy with which they describe the intensity of the damage. The improvement is also justified by the fact that the damage indexes are based on the history of the AE events, and the FAT permits increasing the number of acquired AEs.

Acknowledgments

This work was partially supported by the Italian grant RIDITT, project DI.TR.IM.MIS “Diffusione e trasferimento di tecnologie ad imprese nel settore delle misure”, funded by the Italian Ministry of Economic Development, and partially supported by RELUIS-DPC 2010-2013 Research Project-Research: Line n. 3 - Task 3.1 "Developments and analysis of new materials for the seismic reinforcement of masonry structures", coordinated by prof. L. Ascione and prof. A. Prota.

REFERENCES

- [1] Dudzik, S. (2013). Characterization of material defects using active thermography and an artificial neural network. *Metrol. Meas. Syst.*, 20(3), 491–501.
- [2] Dou, Y., Chang, X. (2012). In-situ automatic observations of ice thickness of seas. *Metrol. Meas. Syst.*, 19(3), 583–592.
- [3] Murugarajan, A., Samuel, G.L. (2011). Measurement, modeling and evaluation of surface parameter using capacitive-sensor-based measurement system. *Metrol. Meas. Syst.*, 18(3), 403–418.
- [4] Zawada-Tomkiewicz, A., Ściegienka, R. (2011). Monitoring of a micro-smoothing process with the use of machined surface images”. *Metrol. Meas. Syst.*, 18(3), 419–428.
- [5] Antoniuk, P., Strąkowski, M.R., Pluciński, J., Kosmowski, B.B. (2012). Non-destructive inspection of anti-corrosion protective coatings using optical coherent tomography. *Metrol. Meas. Syst.*, 19(2), 365–372.
- [6] Zimroz, R., Urbanek, J., Barszcz, T., Bartelmus, W., Millioz, F., Martin, N. (2011). Measurement of instantaneous shaft speed by advanced vibration signal processing-application to wind turbine gearbox. *Metrol. Meas. Syst.*, 18(4), 701–711.
- [7] Ćwikliński, L., Kiciński, W. (2010). Management of memory in a real-time measurement system based on a signal processor. *Metrol. Meas. Syst.*, 17(4), 589–598.
- [8] Bowles, S. J. (1989). AE load-cycle dependence applied to monitoring fatigue crack growth under complex loading conditions. *NDT International*, 22, 7–13.
- [9] Wang, Z. F., Li, J., Ke, W., Zheng, Y. S., Zhu, Z., Wang, Z. G. (1992). Acoustic emission monitoring of fatigue crack closure. *Scripta Metallurgica et Materialia*, 27, 1691–1694.
- [10] Colombo, S., et al. (2005). AE energy analysis on concrete bridge beams. *Materials and structures*, 38, 851–856.

- [11] Hoff, A. B. M, Arrington, M. (1985). Acoustic Emission Monitoring of a Node in an Off-Shore Platform, *Spec Suppl J Acoust Emiss*, 165–170.
- [12] Lamonaca, F., Carrozzini, A. (2010). Monitoring of Acoustic Emissions in Civil Engineering Structures By Using Time Frequency Representation. *Sensors & Transducers journal*, 8, 42–53.
- [13] National Instrument, “NI PCI-6110/6111 Specifications”.
- [14] Lamonaca, F., Carrozzini, A., Grimaldi, D., Olivito, R.S. (2012). Acoustic Emission Monitoring of Damage Concrete Structures by Multi-Triggered Acquisition System. *Proc. of I2MTC 2012 – IEEE International Instrum. and Measurement Technology Conference*, Graz, Austria, 14-16 May, 2012.
- [15] Burr-Brown Corporation, (1992). High Speed FET-Input INSTRUMENTATION AMPLIFIER.
- [16] Analog Devices (2005) “Dual, High Speed ECL Comparators ADCMP563/ADCMP564”, Rev.5.
- [17] Semiconductor Components Industries, LLC (2008). MC10EL01/D, Rev.6.
- [18] National Instrument (2010) “NI FlexRIO FPGA Modules for PXI Express”.
- [19] CEN – European Committee for Standardization (2003) Testing hardened concrete. Compressive strength of test specimens. UNI EN 12390–3, 2003.
- [20] Muravin, B., Acoustic Emission Science and Technology, (2009). *Journal of Building and Infrastructure Engineering*.
- [21] Archana, Nair, Cai, C. S., (2010). Acoustic emission monitoring of bridges: Review and case studies, *Engineering Structures*, 32, 1704–1714.
- [22] Tan, A., Kaphle, M., Thambiratnam, D., (2009) Structural Health Monitoring of Bridges Using Acoustic Emission Technology, *Proc. of 8th International Conference on Reliability, Maintainability and Safety, ICRMS 2009*.
- [23] Kaphle, M.R., Tan, A., Thambiratnam, D. P., Chan, T. H. T., (2011). Study Of Acoustic Emission Data Analysis Tools For Structural Health Monitoring Applications, *J. Acoustic Emission*, 29.
- [24] De Santis, S., Tomor, A. K., (2013). Condition Monitoring Of Masonry Arch Bridges Using Acoustic Emission Technique. *Proc. of 7th international conference on Arch and Bridge*, Croatia, 2013.
- [25] Tsangouri, E., Aggelis, D. G., Van Tittelboom, K., De Belie, N., Van Hemelrijck, D., (2013). Detecting the Activation of a Self-Healing Mechanism in Concrete by Acoustic Emission and Digital Image Correlation. *ScientificWorldJournal*.
- [26] Kaphle, M. R., Tan, A., Thambiratnam, D. P., Chan, T. H. T., (2011). Review: Acoustic Emission Technique - Opportunities, Challenges And Current Work At Qut. *Proc. Of. eddBE2011*.
- [27] B.S EN 13477-2:2001, “Non-destructive testing. Acoustic emission. Equipment characterization. Verification of operating characteristic”, 2001.
- [28] Lamonaca, F., Grimaldi, D., (2012). Trigger Realignment by Networking Synchronized Embedded Hardware. *IEEE Transaction on Instrumentation and Measurement*, Vol.62, Issue 2, 38–49.
- [29] Panin, S.V., Biakov, A. V., Grenke, V. V., Shakirov, I. V. (2008). Automated system for registration, processing and analysis of acoustic emission signals under deformation and fracture. *Proc. of Third International Forum on Strategic Technologies*. IFOST 2008.23-29 June 2008, 455–459.
- [30] Chu-Shu Kao, N. F., Kaveh, M., Tewfik, A., Labuz, A. (2009). Averaged acoustic emission events for accurate damage localization. *Proc. of IEEE Intern. Conf. on Acoustics, Speech and Signal Processing, ICASSP 19-24 April 2009*, 2201–2204.
- [31] Nair, A., Cai, C. S. (2010). Acoustic emission monitoring of bridges: Review and case studies, *Engineering Structures*, 32, 1704–1714.
- [32] Blessing, J. A., Fowler, T. J., Strauser, F. E. (1992) Intensity analysis. *Proc. of 4th Int Symp. on Acoustic Emission from Composite Materials, American Society for Nondestructive testing, Columbus (Ohio)*.
- [33] Chotickai, P. (2001). Acoustic emission monitoring of prestressed bridge girders with premature concrete deterioration. *Masters thesis. Austin (Texas): University of Texas*.