

DESIGN OF A RACE-TRACK COIL FOR MEASUREMENTS OF AC POWER LOSSES IN HIGH-TEMPERATURE SUPERCONDUCTING TAPES

Stanisław Trojanowski¹⁾, Marian Ciszek²⁾, Eduard Maievskiy¹⁾

1) Polish Academy of Sciences, Institute of Low Temperature and Structure Research, ul. Okólna 2, 50-422 Wrocław, Poland (S.Trojanowski@int.pan.wroc.pl, E.Majewski@int.pan.wroc.pl)

2) Wrocław University of Technology, Faculty of Mechanical and Power Engineering, Wybrzeże Wyspiańskiego 27, 50-370 Wrocław, Poland (✉ marian.ciszek@pwr.wroc.pl, M.Ciszek@int.pan.wroc.pl, +48 71 320 48 28)

Abstract

One of the most important parameters, crucial to applications of superconductors in cryo-electrotechnique, is power loss. Measurements of losses in superconducting long sample wires require AC magnetic fields of a special geometry and appropriate high homogeneity. In the paper part of the theoretical basis for calculations and a simple design method for a race-track coil set are presented. An example of such home-made coils, with a magnetic field uniformity of about 0.2 % over the range of about 8 cm, is given. Also a simple electronic measurement system for the determination of AC magnetization loss in samples of superconducting tapes is presented.

Keywords: magnetic field, race-track coil, AC losses, superconducting tapes and wires.

© 2014 Polish Academy of Sciences. All rights reserved

1. Introduction

Widespread use of high temperature superconductors (HTS) in the electric power field would bring many advantages, *e.g.* replacement of expensive liquid helium by much cheaper liquid nitrogen as a cooling medium. Many designs exist for highly efficient transmission cables, motors, transformers, *etc.* [1]. The technical and commercial success of many of these applications depends on the availability of HTS wire or tape in long lengths and with adequate critical current density capabilities and low energy losses.

The intrinsic physical properties of ceramic HTSs determine some technological methods used in manufacturing superconducting wires; *i.e.* they are produced in the form of tapes with a high aspect ratio (even order of 10 000) [2, 3].

Some applications of HTSs are unavoidably connected with the presence of AC currents and AC magnetic fields, which leads to energy dissipation. Thus AC loss is very important as an additional parameter characterizing the technological potential of superconducting materials and the knowledge of power dissipation in a superconducting wire is crucial, at an individual stage of the manufacturing process as well as in ready, working cryogenic power devices.

In general, energy losses are caused by the irreversible motion of the magnetic flux within a superconductor [4, 5]. The flux can originate from an externally applied AC magnetic field (magnetization losses) or from an AC transport current (transport losses).

When measuring AC losses usually the magnetic field is directed perpendicular to a sample tape, and thus perpendicular to the transport current flowing along the tape. So magnetizer coils should meet some of the following requirements:

- The magnetic field created by the coils must possess good uniformity along the whole length of an investigated tape sample (to avoid, *e.g.* end effects). It is not easy to achieve

a highly uniform field in a large space, so the used coils should be elongated in one direction.

- as the coils are usually fed with a sinusoidally varying AC current in order to lower the supplied reactive power to the system, the inductance of the coils should be minimized. It can be achieved by decreasing the surface of the coil turns, and also by elongation of the turns along one direction.
- because we want to measure losses in tapes as a function of the angle between the surface of the tape and the magnetic field direction we must ensure the possibility to rotate the sample around its longer axis.
- easy access from the outside to the measurement space within the magnetizer system is required.

This imposes the need for the magnetizer to be made in the form of a race-track-shaped Helmholtz coil set.

Although there are many commercially available programs for designing various magnets (usually rather quite expensive), sometimes there is an urgent need for a considerably simple and low-cost magnet coils system with reasonable field strength and uniformity. The square shaped Helmholtz coil can be considerably easily calculated from analytical equations based on the Biot-Savart law. Such magnetizer coil calculations are presented in the works [6, 7].

While it is considerably easy to deal with analytical calculations of a square cross-section coil magnetizer, practical construction of such coils is much more difficult than winding the most outer turns gradually take a quasi-circle shape. So calculated values of the magnetic field distribution differ somehow from those obtained in reality. This disadvantage disappears when the coils are in a race-track shape and agreement of the calculated magnetic field with the field really obtained is satisfactory good.

In our work we give a theoretical basis for relatively simple calculation procedures for designing of race-track shaped magnets assembled in the Helmholtz coil set. The final formulas for the magnetic field distributions along the main axis within the coils system are given. Also we present an example of the methodical step-by-step approach to calculation and practical realization of simple and low-cost home-made race-track coils set.

2. Calculation method

In principle, a single wire turn of a race-track coil consists of two parallel straight-line elements closed with two semicircles at their ends. Figure 1 shows a general view of the race-track Helmholtz coils assembly with a coordinate system used in our calculations and a sample tape location for AC loss measurements. Straight line sections of the coils are parallel to the Y -axis and arranged symmetrically with respect to it. The calculations were carried out by summing together all magnetic field contributions originating from the coil straight line segments, and from the semicircular ends as well. Since both coils have the same number of wire turns, the magnetic field generated along the X , Y and Z axes has only the z -component. Other components of the field, due to symmetry, mutually compensate each other. This applies to both magnetic fields, originating from the parallel straight-line and semicircular sections of the wire turns.

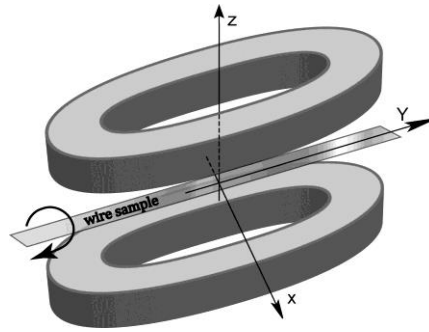

Fig. 1. General view of the Helmholtz race-track coil assembly.

In order to derive the magnetic field and its distribution in a race-track coil system we used the Biot-Savart law in the form

$$d\vec{H} = \frac{I}{4\pi} \frac{d\vec{l} \times \vec{R}}{|\vec{R}|^3}, \quad (1)$$

where $d\vec{H}$ is the elementary magnetic field due to electric current element $I d\vec{l}$, \vec{R} is a vector from the element of current length $d\vec{l}$ to a point P where the magnetic field is to be calculated [8].

2.1. Magnetic field originating from a straight line section of a coil turn

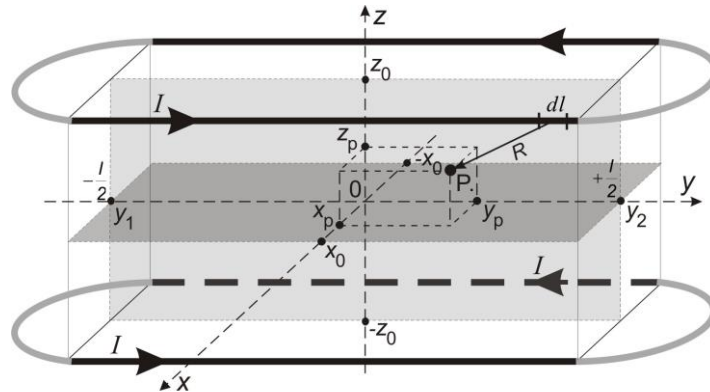

Fig. 2. Schematic view of the race track-coils turns for calculations of the magnetic field originating from the straight line elements. For clarity, only two single wire turns forming the Helmholtz coils system are shown. For parameters see text.

For the straight line parts of a wire turn the Biot-Savart relation (1) gives a magnetic field H at a point P of coordinates (x_p, y_p, z_p) , as:

$$H = \frac{I}{4\pi} \int_{y_1}^{y_2} \frac{d\vec{l} \times \vec{R}}{|\vec{R}|^3}, \quad (2)$$

where y_1 and y_2 are coordinates of the initial point and the terminal point of the straight line segment integration path, respectively (see Fig. 2).

On the coordinate axes X , Y and Z the only non-zero component of the field (H_z) is along the Z -axis, as the other field components vanish due to symmetry of the wire turn. The field component H_z can be determined using the following expression, which is the determinant notation of the vector product $d\vec{l} \times \vec{R}$ in (2):

$$\begin{vmatrix} \hat{x} & \hat{y} & \hat{z} \\ 0 & dy & 0 \\ R_x & R_y & R_z \end{vmatrix} = \hat{x}dyR_z - \hat{z}dyR_x, \quad (3)$$

where $\hat{x}, \hat{y}, \hat{z}$ are the versors of the X, Y and Z -axes, respectively; dy is the y -component of the vector $d\vec{l}$, and R_x, R_y, R_z are the x, y and z -components of the position vector \vec{R} (Fig. 2). The second term on the right-hand side of (3) is an increment of the magnetic field along the Z -axis. Hence, the magnetic field component H_z , derived from the straight line parts of the one wire turn is given by

$$H_z = -\frac{I}{4\pi} \int_{y_1}^{y_2} \frac{R_x dy}{|R|^3} = -\frac{I}{4\pi} \int_{y_1}^{y_2} \frac{(x_p - x_0) dy}{\left[(x_p - x_0)^2 + (y_p - y)^2 + (z_p - z_0)^2 \right]^{1.5}}, \quad (4)$$

where x_0 and z_0 are distances between a cylindrical wire axis and YOZ and XOY planes, respectively (see Figs. 2 and 4). Calculating integral (4) we obtain the value of the z -component of the magnetic field H_z at the point $P(x_p, y_p, z_p)$

$$H_z(x_p, y_p, z_p) = -\frac{I(x_p - x_0)}{4\pi a^2} \left\{ \frac{(y_2 - y_p)/a}{\sqrt{1 + [(y_2 - y_p)/a]^2}} - \frac{(y_1 - y_p)/a}{\sqrt{1 + [(y_1 - y_p)/a]^2}} \right\}, \quad (5)$$

where $a^2 = (x_p - x_0)^2 + (z_p - z_0)^2$.

2.2. Magnetic field originating from a semicircular section of a coil turn

In a similar way one can calculate a component H_z resulting from the semicircular parts of a coil turn. In this case the integration along the arc of the semicircular part of the turn leads to elliptical integrals, which do not belong to the elementary functions class. Here, in order to avoid quite complicated analytical calculations, the problem is simplified by exploiting the Simpson method for numerical integration [9].

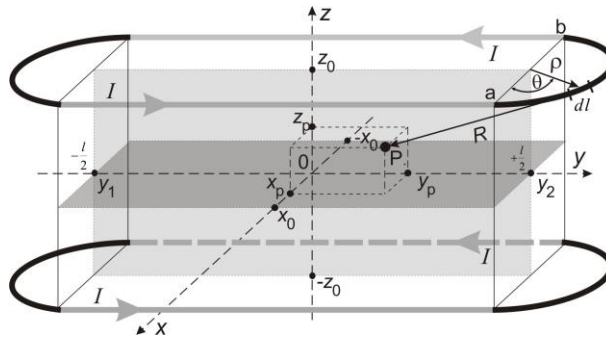

Fig. 3. Schematic view of the race track-coil wire turns for calculations of the magnetic field distribution originating from the semicircular ends of the coil turn.

As seen in Fig. 3 the integration path element $d\vec{l}$ runs along an arc with the radius ρ . The variable $d\vec{l}$ in the polar coordinate system can be expressed by means of the Cartesian coordinate system as $d\vec{l} = (-\hat{x}\rho \sin\theta + \hat{y}\rho \cos\theta)d\theta$; hence we get the expression for the Biot-Savart law

$$H(x_p, y_p, z_p) = \frac{I}{4\pi} \int_a^b \frac{d\vec{l} \times \vec{R}}{|\vec{R}|^3}, \quad (6)$$

where a and b are the initial and the terminal points of the integration, respectively. \vec{R} is a position vector connecting the point P at which the magnetic field is to be derived with the integration path element $d\vec{l}$. Expressing the vector product under the integral sign in the determinant form we get the z -component of the magnetic field

$$\begin{pmatrix} \hat{x} & \hat{y} & \hat{z} \\ -\rho \sin \theta d\theta & \rho \cos \theta d\theta & 0 \\ R_x & R_y & R_z \end{pmatrix} = -\rho \sin \theta d\theta R_y - \rho \cos \theta d\theta R_x.$$

Hence, an increment of the z -component of the magnetic field, dH_z can be derived using the differential form of the Biot-Savart law

$$dH_z(x_p, y_p, z_p) = -\frac{I}{4\pi} \frac{\rho \sin \theta R_y + \rho \cos \theta R_x}{|\vec{R}|^3} d\theta, \quad (7)$$

In order to avoid elliptical integrals the equation (7) can be solved with the help of the Simpson integration method [9]. The method allows to integrate (7) in a simple manner and with highly satisfactory accuracy for our purpose. According to notations in Fig. 3, the integration on the right-hand side semicircle is performed for the angles $0 \leq \theta \leq \pi$, and for $R_x = x_p - \rho \cos \theta$, $R_y = y_p - \rho \sin \theta - l/2$ and $R_z = z_p - z_0$. On the left-hand side of the turn semicircle the integration is performed for the angles $\pi \leq \theta \leq 2\pi$, and for $R_x = x_p - \rho \cos \theta$, $R_y = y_p - \rho \sin \theta + l/2$ and $R_z = z_p - z_0$. In both cases $|\vec{R}| = \sqrt{R_x^2 + R_y^2 + R_z^2}$, z_0 is the distance of the wire center from the XOY plane and ρ is the radius of a semicircle part of a magnet coil turn (see Fig. 3 and 4).

In order to achieve sufficient accuracy of the integral, the numerical calculations are performed over the variable θ with a step of one degree, *i.e.* $\pi/180$ radian. Such derived increments of the Z -axis magnetic field component dH_z , resulting from an individual part of the coil turn, are added up over all of the wire turns as well as over all layers of the coil. In that way we obtain the resultant component H_z of the magnetic field along the Z -axis at a given point of coordinates (x_p, y_p, z_p) . Along the axis X , Y , and Z of the two race-track coils assembly only the component H_z takes non-zero values. The other components (H_x and H_y) vanish due to symmetry of the coils system.

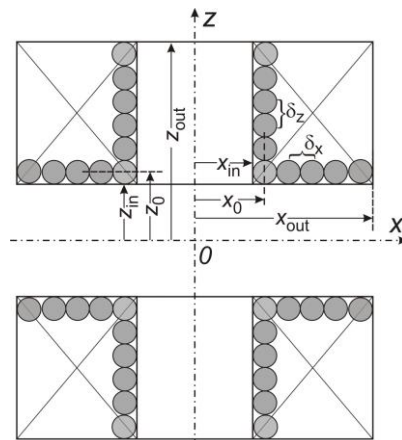

Fig. 4. Cross-section view along the XOY plane of the Helmholtz race track coil system. Some parameters used in magnetic field calculations (see text) are also shown.

The computation algorithm used by us was divided into two parts. The first part is for analytical calculation of the z -component of the magnetic field, H_z , projected onto one of chosen axes X , Y , and Z , and originating from all straight-line segments of all wire turns. This computation procedure is expressed by the following relation:

$$\frac{H_z(0, y, 0)}{I} = \sum_{j=0}^{N_x-1} \sum_{k=0}^{N_z-1} \frac{x}{b} \left(\frac{b_1}{\sqrt{b+b_1^2}} + \frac{b_2}{\sqrt{b+b_2^2}} \right), \quad (8)$$

The equation is for the H_z -component along the Y -axis and for conditions that $|y| \leq l/2$, $x = x_0 + j\delta_x$, $z = z_0 + k\delta_z$, $b_1 = l/2 - y$, $b_2 = l/2 + y$, $b = x^2 + z^2$, and where N_x is the number of wire turns along the X -axis (number of layers in a coil), N_z is the number of wire turns along the Z -axis (number of turns in a layer), x_0 is the distance of the most inner layer of the coil from the YOZ plane, z_0 is the distance of the first wire turn from the plane XOY , δ_x is the separation between the wire turns along the X -axis (the distance between coil's layers), δ_z is the separation between the turns along the Z -axis (the distance between turns in the layer). These parameters are shown in Fig. 4 and Table 1.

The second part of the computation algorithm allows to determine, here by the Simpson numerical integration method, the z -component of the magnetic field, H_z , projected onto the Y -axis and originating from all semicircular ends of wire turns:

$$\begin{aligned} \frac{H_z(0, y, 0)}{I} = & \frac{1}{540} \sum_{j=0}^{N_x-1} \left\{ \frac{1}{\rho} \sum_{k=0}^{N_z-1} \left[4 \sum_{m=1}^{45} \left(\frac{1+b_0 \sin((2m-1) \cdot \pi/180)}{1+2b_0 \sin((2m-1) \cdot \pi/180)} + b_0^2 + z^2 \right)^{1.5} + \right. \right. \\ & + \left(\frac{1+b_1 \sin((2m-1) \cdot \pi/180)}{1+2b_1 \sin((2m-1) \cdot \pi/180)} + b_1^2 + z^2 \right)^{1.5} + 2 \sum_{m=1}^{44} \left(\frac{1+b_0 \sin(m \cdot \pi/90)}{1+2b_0 \sin(m \cdot \pi/90)} + b_0^2 + z^2 \right)^{1.5} + \\ & + \left. \left(\frac{1+b_1 \sin(m \cdot \pi/90)}{1+2b_1 \sin(m \cdot \pi/90)} + b_1^2 + z^2 \right)^{1.5} + \frac{1}{(1+b_0^2 + z^2)^{1.5}} + \frac{1}{(1+b_1^2 + z^2)^{1.5}} + \right. \\ & \left. \left. + \frac{(1+b_0)}{(1+2b_0 + b_0^2 + z^2)^{1.5}} + \frac{(1+b_1)}{(1+2b_1 + b_1^2 + z^2)^{1.5}} \right] \right\}, \quad (9) \end{aligned}$$

where $\rho = x_0 + j\delta_x$, $b_0 = (l/2 - y)/\rho$, $b_1 = (l/2 + y)/\rho$, $z = (z_0 + k\delta_z)/\rho$ and $|y| \leq l/2$. In a very similar way one can easily find analogous solutions for the z -components of the magnetic field along the X and Z axes.

3. Example of a race-track coil set

When designing a system of the race-track coils for measurements of AC losses in superconducting tapes, we must make some preliminary assumptions, such as:

- maximal dimensions (the length and the width) of sample tapes to be investigated
- maximal allowable size of the coil set
- maximal value of the magnetic field produced in the geometric center of the coil set
- required homogeneity of the magnetic field along the main symmetry axis of the coil set
- cross section area of the winding wire
- maximal permissible current density in the coil winding (here approximately 3 A/mm² accepted for Cu at a temperature of 300 K and about 12 A/mm² at 77K).

At this stage of the design we also have to include parameters of the voltage-current output of the AC power supply being at our disposal. This allows the choice of the optimal diameter and length of the winding wire, hence determination of its electrical resistance.

In order to obtain optimal geometrical parameters of the race track coils Helmholtz set for computation (equations (8) and (9)) we adopted the trial-and error method. By choosing a length of the straight-line elements of the coil's turn, their separation distance, heights of the coils, separation between the coils system etc., spatial uniformity of the generated magnetic field and its strength can be obtained in accordance with our requirements. The lower limit for the coil size is given by dimensions of the superconducting sample tapes to be investigated. In order to meet requirements for the assumed field homogeneity on the symmetry axis of the coil system one has to increase their total size value for which these requirements are satisfactory fulfilled. To obtain the required value of the maximal magnetic field at the center of the coils we further have to increase the number of the coil wire turns and the number of layers. We derive the maximal value of the field obtained in the system from the calculated magnet constant and maximal allowable current flowing through the coils. In the case of long superconducting tapes it is most important to ensure sufficient uniformity of the magnetic field component H_z along the Y -axis. To achieve this requirement one can change the length of the straight line segments of a coil turn (l), their separation ($2x_0$) and the distance between the two coils of the Helmholtz system ($2z_0$). By varying the values of these parameters we are able to achieve the desired field homogeneity along the Y -axis. Field inhomogeneities along the X and Z -axes are much less sensitive to the parameters of the coils, particularly to the l -value. In order to change the X and Z -axes field distributions one has to vary distances x_0 and z_0 . This, however, also changes the field uniformity along the Y -axis. All these changes affect the value of the magnet constant as well. So an optimal and satisfactory parameter set is required, depending on AC loss measurement conditions. These calculation procedures are repeated many times until a satisfactory final result is obtained. In accordance with the design procedure presented above, an optimal set of race-track coils set parameters was obtained.

The coils allow measuring AC losses in superconducting tapes of the length of about 10 cm and in magnetic fields with assumed homogeneity. Some parameters of the coils are given in Table 1.

Table 1. Parameters of exemplary race-track coil.

Parameter	value
Number of layers, N_x	22
Number of turns in a layer, N_z	26
l (mm)	150
x_0 (mm)	21
δ_x (mm)	1.91
z_0 (mm)	24
δ_z (mm)	2.12
Cu wire cross-section area, mm ²	1.65
Magnet constant, k_m (mT/A)	5.15

After the examination procedure of magnetic field distributions obtained by us we selected finally the following parameters: length of the straight internal section of the turn $l=150$ mm, radius of the semicircular rounded ends, $\rho=20$ mm (see Fig. 3), internal width (separation of the straight line segments) of the wire turn $2x_{in}=40$ mm, external width of the coil windings $2x_{out}\approx 125$ mm, the distance between the inner edges of the coils $2z_{in}=46$ mm, the distance of the outer edges of the coils $2z_{out}=156$ mm. For more details see Fig. 4 and Table 1.

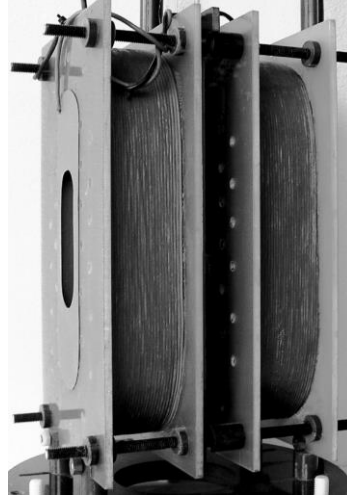

Fig. 5. Home-made race-track coils system.

Fig. 5 presents a general view of our home-made coils. The coils were wound with copper litz wire consisting of 210 twisted filaments with a diameter of 0.1 mm each, effective outer wire diameter of 2.01 mm and cross-section area of 1.65 mm², coated with silk. Using litz wire allows significant reduction in induced eddy currents in copper and thus minimizes the phase shift obtained by the coil windings and the electric current produced by an effective, variable magnetic field. The electrical resistance of the coils at temperature of liquid nitrogen (about 77.3K) is around 1 Ω, and the self-inductance is 0.11 H. To avoid mechanical vibrations, the windings are impregnated with the Stycast 2850 resin. In addition, this resin significantly improves the conduction of the generated heat to the nitrogen bath.

Fig. 6 presents the results obtained experimentally and, for comparison, the theoretically-derived distributions of this component of the magnetic field on the y-axis for a few selected distances between the coils, 2z₀.

The intensity of the magnetic field values presented here was normalized to the value of the field in the geometric center of the coils. The observed differences are perhaps due to two factors: the magnetic field measured by sensors (*e.g.* finite size of Hall probes or pick-up coils, when measured by inductive methods) is averaged over a certain space, and the second one due to some unavoidable uncertainties of the coil windings. As shown in Fig. 6, these differences are so small that our proposed method of designing coils should be regarded as quite effective.

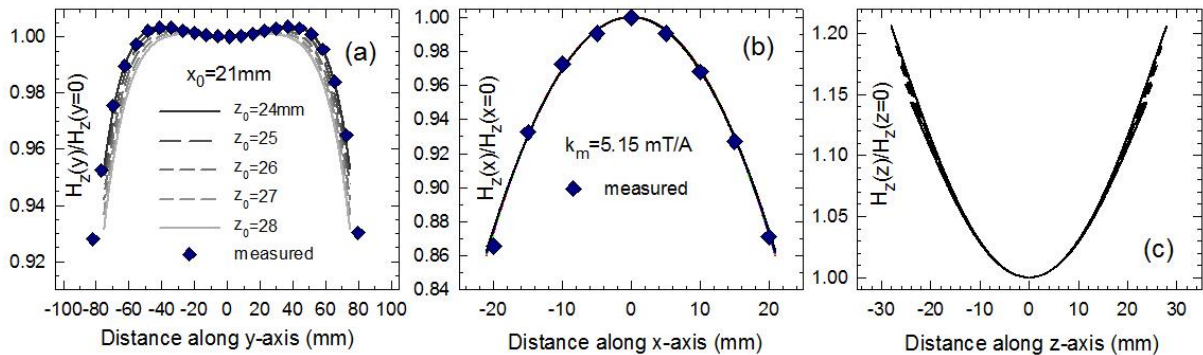

Fig. 6. Calculated (lines) and determined experimentally (points) H_z -magnetic field component distributions along three main axes X, Y, Z, as a function of the coils separation distance z_0 . The magnetic field values are normalized to the value of the field in the geometrical center of the coils assembly.

The magnetic field constant for our coils system is about 5.15 mT/A and it depends (as well as magnetic field uniformity) on the spatial distance between the coils. The inhomogeneity of the obtained magnetic field along the *Y*-axis over a distance of 80 mm is only about $\pm 0.18\%$. It depends on the separation distance between the coils ($2z_0$).

A simple TurboBasic code which allows to calculate a race-track coil according to the design approach presented here is available on request from the authors.

As investigated here, superconducting samples are in shapes of narrow tapes or thin round wires; it is most important to provide sufficiently high magnetic field homogeneity only along the *y*-axis. The advantages of the race-track coils over the round or square shape of Helmholtz coils are quite remarkable. Simple calculations show that for the same magnetic field parameters (e.g. homogeneity, magnet constant, inductance, etc.) one should make a round shaped Helmholtz coil with an average diameter of about 40 cm, with an inductance of 1 H and resistance of about 3.5 Ω at 77.3 K. Such big coils need to be powered by considerably higher AC current supplies.

4. AC magnetization losses measurement system

Race-track coils described above and made by us are used in a system for measurement of AC magnetization losses in composite tape wires made of high temperature superconductors (here commercially available tape YBaCuO-123 manufactured by the SuperPower-Furukawa Company). A block diagram of the system here used is given in Fig. 7.

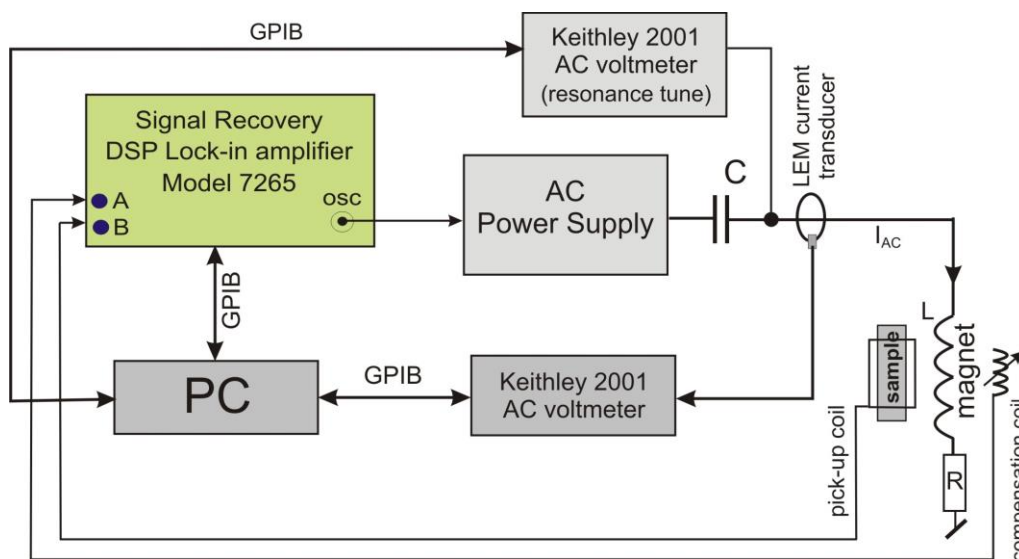

Fig. 7. Block diagram of the AC magnetization losses measurement system. For details see text and Fig. 8.

The race track coils are the source of a sinusoidally varying magnetic field in the form of $b = b_0 \sin 2\pi ft$, with the maximal amplitude of about 100 mT at a frequency f up to around 100 Hz. The magnet coils current is controlled by a voltage signal coming from the internal generator of the dual-phase Signal Recovery Lock-in voltmeter model 7265. This signal is amplified to the current through a high power current source (e.g. bipolar KEPCO model BOP 20-50MG). The current through a battery of capacitors (they assure a series resonance condition) is fed to the magnet coils and its value is measured by means of a Hall effect current transducer. A LabView platform program controls the whole measuring system.

AC magnetization losses were measured by means of a standard digital lock-in technique. A measured superconducting sample tape is placed inside the race-track magnet coils system.

In order to measure magnetization losses a rectangular, one turn, saddle shaped pick-up voltage coil is wrapped around the investigated sample with a special geometry. The external AC magnetic field was oriented perpendicularly to the plane of the sample (see Fig.8).

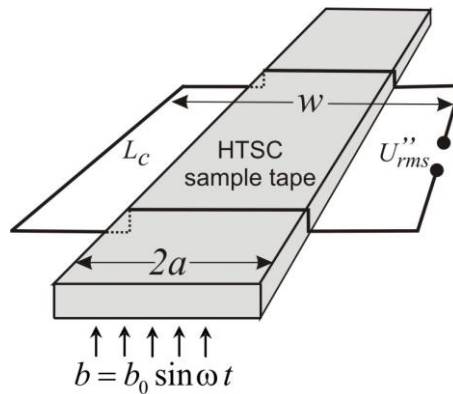

Fig. 8. Arrangement of the sample tape with a saddle pick-up coil. The external magnetic field b is oriented perpendicularly to the plane of the sample of the width $2a$. The pick-up sensing coil of the width w and the length L_c is wrapped around the tape. The loss voltage U''_{rms} is measured by the lock-in amplifier in phase with the external magnetic field b .

Due to strong nonlinear magnetic properties of type-II superconductors, especially ones with a high aspect ratio (*e.g.* thin film strips) placed in a perpendicular magnetic field, information about AC magnetization losses is present also in the space around the superconductor. Thus, to obtain an unambiguous magnetization loss measurement we need to sample the magnetic flux over a distance much larger than the strip width [10]. However for practical purposes quite a small loop will be adequate. In our case the width of the pick-up coil was about three times the sample strip's width (the width of the tape was 4 mm). Such geometry allows measuring magnetic losses within a few percent of the "true" loss [11, 12].

The loss component U''_{rms} of the voltage signal (in phase with the phase of the external magnetic field), at the fundamental frequency, induced in the pick-up coil was measured by using a digital dual phase lock-in amplifier. The inductive (out of phase) component of the voltage measured in the pick-up coil, which is usually much higher than the loss voltage, must be properly compensated in order to avoid saturation of the lock-in channels. For this purpose an extra empty small coil is used, located far from the sample (a compensating coil). The voltage signal, which is believed to be purely inductive in nature (shifted by 90 deg with respect to the external magnetic field) is applied to the second input terminal of the lock-in amplifier and subtracted from the inductive component of the voltage from the pick-up coil. Special precautions should be taken to set the phase and avoid common mode signals (*i.e.* grounding only in one common point). Filters ensured that only the fundamental was measured; the harmonics do not contribute to the loss. For higher signal frequencies (around 100 Hz and above) we used a filter time constant of 200 ms whereas 500 ms for lower field frequencies. Measurements were averaged over 30 runs for higher field amplitudes *i.e.* higher loss voltage signals. The number of averages was increased subsequently as the measured loss voltages decreased, and for the lowest magnetic field amplitudes it reached 200. All measurements were carried out at liquid nitrogen temperature. The sensitivity of our apparatus was better than 10^{-8} V, which corresponds to an energy loss of about 1 nanojoule/meter/Hz. As our superconducting sample wires are quite small, the measured loss voltages are small too (of the order of nV). For this reason we used a sensitive lock-in voltmeter. For measurements with larger samples and higher magnetic fields other lock-in electronic systems can be adopted [13].

The apparent loss Q_m , per cycle, per unit length of the sample tape, was calculated using the formula:

$$Q_m = C \frac{\pi w}{2L_c f} U_{rms}'' H_{rms}, \quad (10)$$

where w and L_c are the pick-up coil width and length, respectively; U_{rms}'' is the loss voltage from the pick-up coil; and H_{rms} is the external magnetic field of the frequency f . The calibration factor C is a function of the ratio $w/2a$ and goes to unity when $w/2a \rightarrow \infty$ [11,12]. In our case, for $w/2a=3$ the factor C is about 0.962.

As an example, measured magnetization losses Q_m , per cycle, per unit length, are shown in Fig. 9.

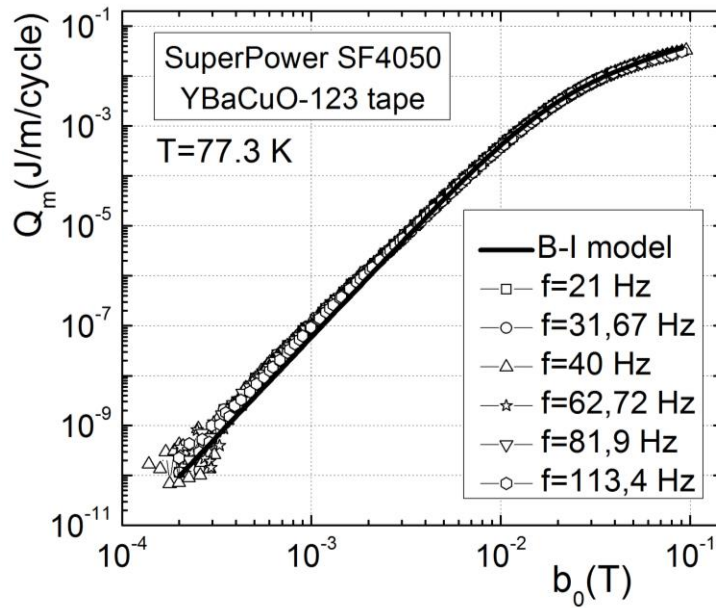

Fig. 9. AC magnetization losses Q_m versus magnetic field amplitude b_0 , for different frequencies (21 to 113.4 Hz). The solid line (B-I) is according to the Brandt-Indenbom theoretical model [14].

In general they do not change with the applied magnetic field frequencies. Such hysteretic loss behavior indicates that the main contribution to the magnetization losses comes from YBCO-123 high temperature superconductors. The solid lines shown here represent the theoretical model for AC magnetization losses in a thin strip, subjected to an external perpendicular magnetic field [14]. According to this model, magnetization losses Q_m , per unit length and per cycle, in a strip of width $2a$ and with the critical current I_c , are given by:

$$Q_m = \frac{1}{\mu_0} 4\pi a^2 b_0^2 \cdot \frac{1}{x} \left[\frac{2}{x} \ln \cosh(x) - \tanh(x) \right], \quad (11)$$

where $x=b_0/B_c$; B_c is a characteristic field defined as $B_c=\mu_0 I_c/2\pi a$, and I_c is the critical current (here for our tape $I_c=107$ A). The model was derived for an isolated single superconducting strip, with a critical current density independent of the magnetic field. From (2) for $x \ll 1$, it results that the magnetic losses follow a $Q_m \approx b_0^4$ dependence, whereas for the higher magnetic field amplitudes they are linear with b_0 . As it is seen, experimental results obtained with the help of our measurement system using home-made magnet coils are in very good agreement with theoretical predictions.

5. Conclusions

Measurements of the losses in superconducting long sample wires require AC magnetic fields of special geometry and appropriate high homogeneity. In the paper some of the theoretical basis for calculations and a simple designing method for a race-track coil set are given. An example of such home-made coils, with magnetic field uniformity of about 0.18 % over the range of about 8 cm is presented. Also a simple electronic measurement system for AC magnetization loss determination in samples of high- T_c superconducting tapes, at the temperature of a liquid nitrogen bath is given. A simple TurboBasic code which allows to calculate a race-track coil according to the design approach presented here is available on request from the authors.

References

- [1] Sheahen, T. P. (1994). *Introduction to high temperature superconductivity* New York: Plenum Press.
- [2] Grant, P. M. (1997). Superconductivity and electric power. *IEEE Trans. Appl. Super.* 7 112–132.
- [3] Teranishi, R., Izumi, T., Shiohara, Y. (2006). Highlights of coated conductor development in Japan. *Supercond. Sci. Technol.* 19, S4–S12.
- [4] Wilson, M. N. (1993). *Superconducting magnets*, London, Oxford University Press.
- [5] Carr, W. J. Jr. (2001). *AC loss and macroscopic theory of superconductors* London: Taylor@Francis, 2nd ed.
- [6] Chen, D. X. (2004). High-field ac susceptometer using Helmholtz coils as a magnetizer. *Meas. Sci. Technol.* 15, 1195–1202.
- [7] Alamgir, A. K. M., Fang, J., Gu, C., Han, Z. (2005). Square Helmholtz coil with homogeneous field for magnetic measurement of longer HTS tapes. *Physica C* 424, 17–24.
- [8] Jackson, J. D. (1999). *Classical Electrodynamics*, New York, John Wiley & Sons, 3rd ed.
- [9] Dahlquist, G., Björck, A. (2008). *Numerical Methods in Scientific Computing*, Philadelphia, SIAM, vol. 1, Chapter 5, 521–607.
- [10] Campbell, A. M. (1995), AC losses in high T_c superconductors. *IEEE Trans. Appl. Supercond.* 5 (2), 682–687.
- [11] Yang, Y., Martinez, E., Norris, W. T. (2004). Configuration and calibration of pickup coils for measurement of ac loss in long superconductors. *J. Appl. Phys.* 96, 2141–2149.
- [12] Nguyen, D. N., Sastry, P. V. P. S., Knoll, D. C., Schwartz, J. (2006). Electromagnetic and calorimetric measurements for AC losses of a $YBa_2Cu_3O_{7-\delta}$ coated conductor with Ni-alloy substrate. *Supercond. Sci. Technol.* 19, 1010–1017.
- [13] Kotarski, M., Smulko, J. Assessment of synchronic detection at low frequencies through DSP-based board and PC sound card. *Proc. XIX IMEKO World Congress Fundamental and Applied Metrology*, Sept. 6-11, 2009, Lisbon, Portugal, pp. 960–963.
- [14] Brandt, E. H., Indenbom, M. (1993). Type-II superconductor strip with current in a perpendicular magnetic field. *Phys. Rev. B* 48 (17), 12893–12906.