

THE CHOICE BETWEEN ANALOG OR DIGITAL AC POWER MEASUREMENT IN A VODAFONE BASE STATION DATA LOGGER

Francisco Corrêa Alegria¹⁾, Francisco Martins Travassos²⁾

1) Instituto de Telecomunicações e Instituto Superior Técnico, Av. Rovisco Pais, 1, 1049-001 Lisbon, Portugal (✉ falegria@lx.it.pt, +351 218 418 376)

2) Nokia Siemens Networks Portugal, Rua Irmãos Siemens, 1, 2720 - 093 Amadora, Portugal (ciscotravas@gmail.com)

Abstract

A data logger has been built to record, for a month, the power consumption of various equipment and the temperature at different points inside and outside of a radio communication base station operated by Vodafone Portugal. Here we show how the concerns with measurement uncertainty led us to choose an analog system over a digital one for AC power measurement.

Keywords: AC power measurement, automatic system, data logging.

© 2010 Polish Academy of Sciences. All rights reserved

1. Introduction

The introduction of analog-to-digital converters (ADCs) and microprocessors, including digital signal processors (DSP) and microcontrollers, has brought a new realm of possibilities for measurement systems. In [1], for instance, both analog-to-digital and digital-to-analog converters are used, together with a microprocessor, to precisely measure RMS voltage. In some cases multiple microprocessors are used to allow more flexibility and real time operation of measurement systems [2].

Physical quantities are inherently analog. Before analog-to-digital conversion they are generally filtered to remove noise and unwanted signals, amplified to increase the signal-to-noise ratio, adjusted in order to have a linear relation between output voltage and the measured quantity and mathematically transformed or combined in order to estimate same derived quantity. These benefits can also be obtained in the digital domain with digital signal processing. It is not always clear, however, if these operations are more advantageously carried out in the analog or in the digital domain. Naturally the finite ADC resolution, sampling frequency and number of acquired samples introduce additional sources of uncertainty that play to degrade the measurements made. Aliasing, for instance, is another example of the problems that the use of ADCs entails and which the designer should be aware of [3].

This paper focuses exactly on this kind of choice, namely in the case of active power measurement. Active power is a derived quantity obtained from voltage and current measurements. It can be measured in the analog or in the digital domain:

- Analog – Multiply the voltage and current with an analog multiplier, use a low-pass filter to extract the mean of the result and acquire the DC voltage at the filter output with the ADC of a microcontroller. This voltage is proportional to the active power.

- Digital – Acquire the two waveforms (voltage and current) with a microcontroller containing an ADC, multiply by software, point by point, the two sample arrays and compute the average value.

We seek to determine to what extent it should be carried out in the analog or in the digital domain. To that effect we derive theoretical expressions for the standard deviation (precision) of the active power measurements made in the analog and in the digital domain in order to compare the two approaches.

In this paper we give an example of a data logger built for a specific purpose namely to measure the energy consumption of different radio-frequency equipment used in a Vodafone radio communication base station (BTS) [4]. It measures, among other things, three phase AC active power in the analog domain. The ultimate purpose of this data logger is to use the gathered information, together with data about the number of calls made in a given period of time, to study how the operation of the base station can be optimized in order to reduce operational costs.

In Section 2 we present briefly the data logger built. More detailed information can be found in [4]. In Section 3 we describe the analog AC power measurement circuit that was built and used. As demonstrated in Sections 4 and 5 this is the solution that leads to a lower uncertainty. Finally, in Section 6 we present some conclusions.

2. Data Logger

Inside a BTS there is various radio communication equipment (RBS) for second- (2G) and third- (3G) generation networks. The equipment needs a DC supply and thus the BTS also has a rectifier to convert the AC voltage supplied to the BTS (250 V, 50 Hz) to a DC voltage (50 V). To keep the BTS working in case of power supply failure, it is equipped with a set of batteries for energy storage. It also has an air conditioning unit to keep the temperature inside the BTS low enough for proper operation of the radio communication equipment and batteries.

To study the efficiency of the base station, we wanted to analyze the efficiency of the rectifiers, the distribution of the energy consumption among the different equipment inside the base station and to measure the individual energy consumption of each radio communication equipment so that it could be correlated to the voice and data traffic going through the BTS.

Another important concern was the optimization of the air conditioning unit operation. The less time it operated the less energy it would consume. It is also important that the temperature of the batteries be kept between 25 °C and 27 °C so as not to diminish their lifetime.

After analyzing some typical base stations the following list of required measurements was compiled:

- The energy consumed by the entire station (AC tri-phase);
- The energy consumed by the rectifiers (AC tri-phase);
- The energy consumed by the air conditioner (AC tri-phase);
- The energy consumed by 3 radio communication equipment units (DC);
- Temperature at several points around the base station.

Also a list of desirable features was put together consisting of the following abilities:

- Be able to store the results for posterior analysis;
- Be able to monitor the measurements made without interrupting the measuring system operation;

- Be able to install the system in a BTS without interrupting the DC power supply to the radio-frequency equipment;
- Be able to keep track of time even if the power supply of the measuring system was briefly interrupted;
- Do not occupy a large space inside the BTS;
- Be light so that it could be easily moved from BTS to BTS;
- Be inexpensive.

In Fig. 1 a block diagram is presented containing the components of the system.

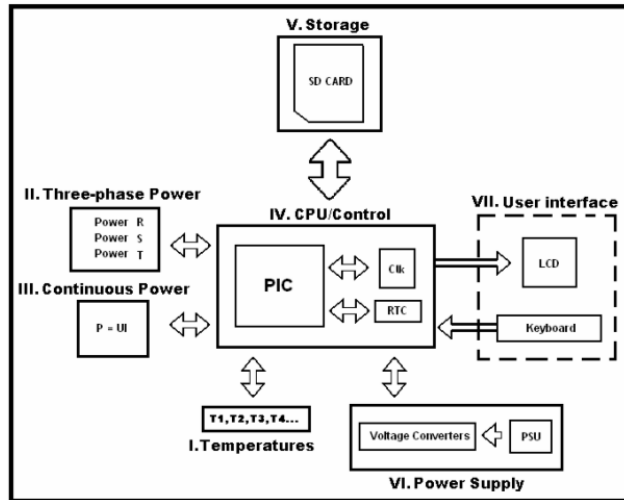

Fig. 1. Block diagram of the measurement system.

The measurement system was built around a microcontroller. One from Microchip, model PIC18LF8722 [5], was chosen since it is a low cost microcontroller which has 16 analog inputs as well as SPI and I²C interfaces needed to communicate with a Secure Digital Card which would store the measurement results and a real time clock to keep track of time.

The microcontroller (PIC) used is powered with 3.3 V and needs an external 20 MHz clock. The 16 available 10-bit analog inputs were used as follows:

- Two, three-phase, power measurement modules: 6 inputs;
- Three DC power measurement modules (common voltage): 4 inputs;
- Six-point temperature measurement module: 6 inputs.

3. Analog AC Power Measurement

The rectifier and the air conditioning unit work with a 230 V three-phase system. The energy consumed by those systems is determined by measuring the active power drawn and integrating it through time. To measure the active power we use the three-wattmeter method that consists in measuring the active power in each phase separately [6]. The active power (P) is determined from the measured voltage (v) and current (i). By definition it is the mean value of the product of voltage and current:

$$P = \frac{1}{T} \int_0^T v(t)i(t)dt, \quad (1)$$

where the mean is taken over one period (T) of the signal.

In the case where the voltage and current are sinusoidal signals:

$$v(t) = V \cos(\omega t + \varphi_V) \quad (2)$$

and

$$i(t) = I \cos(\omega t + \varphi_I), \quad (3)$$

respectively, where V and I are their amplitudes and φ_V and φ_I are their initial phases, the active power is given by:

$$P = \frac{1}{2}VI \cos(\varphi_V - \varphi_I). \quad (4)$$

Two Hall Effect sensors are used to convert the high voltage and current to small proportional voltages. We thus have:

$$v_V(t) = K_V v(t) = K_V V \cos(\omega t + \varphi_V) \quad \text{and} \quad v_I(t) = K_I i(t) = K_I I \cos(\omega t + \varphi_I). \quad (5)$$

The Hall effect transducers used to sample the voltage and current were the LV25-P [7] and the LA25-NP [8] respectively from LEM USA. The LV25-P is a Hall effect closed cycle transducer which works with DC or AC signals up to 500 V. It has galvanic isolation between the primary circuit (high voltage) and the secondary one (electronics) and a theoretical conversion factor of 2500:1000. It needs a power supply between ± 12 and ± 15 V.

The LA25-NP is also a Hall effect closed cycle transducer which works with DC or AC signals up to 25A. It also has a galvanic isolation between the primary circuit and the secondary one. The power supply is also between ± 12 V and ± 15 V. It is accurate and linear such as the LV 25 P.

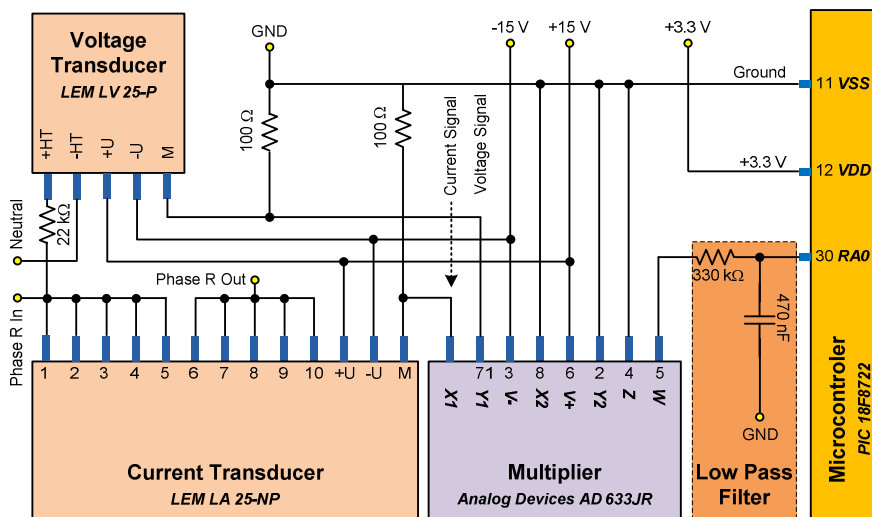

Fig. 2. Electric circuit for the analog AC power measurement solution.

In Fig. 2 we show how to connect the current transducers to the rest of the circuit. Note that the current transducer is placed in series with the phase whose current is to be measured. The output of the current sensor is the current out of terminal “M” with a nominal value of 25 mA when the primary current has an effective value of 25 A. Other nominal values may be

used if the connections between pins 1 through 10 are changed as indicated in the manufacturer data sheet. In order to produce a voltage, a measuring resistance of 100Ω was used which leads to a nominal voltage of 2.5 V which is inside the range of the multiplier to which it is connected. The constant K_I in (5) is thus 0.1 V/A.

The voltage sensor needs a resistance in series with the “+HT” terminal to produce a current which should be in the order of 10 mA. Since the phase effective voltage is 230 V, a resistance of 22 k Ω was used. The sensor output is also a current out of terminal “M” (with 25 mA nominal value) which is converted to a voltage with the help of another 100 Ω resistance. The constant K_V in (5) is thus 4.545×10^{-3} .

For the multiplier we consider using model AD633JR from Analog Devices [9]. Its output voltage is given by:

$$v_{mult}(t) = K_M (X_1 - X_2)(Y_1 - Y_2) + Z, \quad (6)$$

where $X_{1,2}$, $Y_{1,2}$ and Z are inputs of the multiplier. Connecting inputs X_2 , Y_2 and Z to ground and using inputs X_I and Y_I for the voltages output from the Hall Effect transducers, leads to:

$$v_{mult}(t) = \frac{1}{2}VIK_V K_I K_M + \frac{1}{2}VIK_V K_I K_M \cos(2\omega t + \varphi_V + \varphi_I) + n_{mult}(t), \quad (7)$$

where n_{mult} is the voltage noise introduced by the multiplier with a spectral density of η_{mult} . Constant K_M in this instance is 0.1 V^{-1} . According to the manufacturer specifications the spectral density of the noise introduced by the multiplier is $0.8 \mu\text{V}/\sqrt{\text{Hz}}$.

This signal is then low-pass filtered to remove the sinusoidal component and keep its DC value. The result is:

$$v_{filt}(t) = \frac{1}{2}VIK_V K_I K_M G + filt(n_{mult}(t)) + filt(n_{lpf}(t)), \quad (8)$$

where G is the filter gain at DC and $filt$ is the noise transfer function of the low-pass filter.

The ADC acquires M samples of this signal adding its own noise (n_{ADC}). If we consider this noise to be equivalent to an additive voltage at the ADC input, we have:

$$v_{ADC}(t) = v_{filt}(t) + n_{ADC}(t) = \frac{1}{2}VIK_V K_I K_M G + filt(n_{mult}(t)) + filt(n_{lpf}(t)) + n_{ADC}(t). \quad (9)$$

Finally, in software, the average value is computed and divided by $K_V K_I K_M G$ to obtain the active power.

$$P = \frac{1}{K_V K_I K_M G} \times \frac{1}{M} \sum_{i=1}^M v_{ADC}(iT_s). \quad (10)$$

Inserting (9) into (10) leads to:

$$P = P + \frac{1}{K_V K_I K_M G M} \left[\sum_{i=1}^M n_{mult}(iT_s) \sqrt{B} + n_{lpf}(iT_s) \sqrt{B} + n_{ADC}(iT_s) \right]. \quad (11)$$

Since the noise terms have a null mean, it is easily seen that this estimator is unbiased, that is:

$$E\{P\} = P. \quad (12)$$

From (11) we can compute the variance of the estimator considering that the 3 noise terms are independent and that each sample is not correlated with the other samples. We have thus:

$$VAR\{P\} = \frac{1}{(K_V K_I K_M G)^2 M} \times (\eta_{mult}^2 B + \eta_{lpf}^2 B + \sigma_n^2), \quad (13)$$

where σ_n is the ADC noise standard deviation, B is the low pass filter equivalent noise bandwidth.

The standard deviation of the estimated active power becomes, from (13),

$$\sigma_P = \frac{1}{K_V K_I K_M G \sqrt{M}} \times \sqrt{\eta_{mult}^2 B + \eta_{lpf}^2 B + \sigma_n^2}. \quad (14)$$

It is observed that the three noise terms add up to each other in contributing the precision of the active power estimation and that this precision can be improved by increasing the number of samples. We can also conclude that narrower filter bandwidths lead to more precise estimates (lower standard deviation).

4. Digital Measurement

In the Digital Solution, the two voltages that come out of the Hall effect transducers are immediately digitized using the ADC inside the microcontroller (Fig. 3).

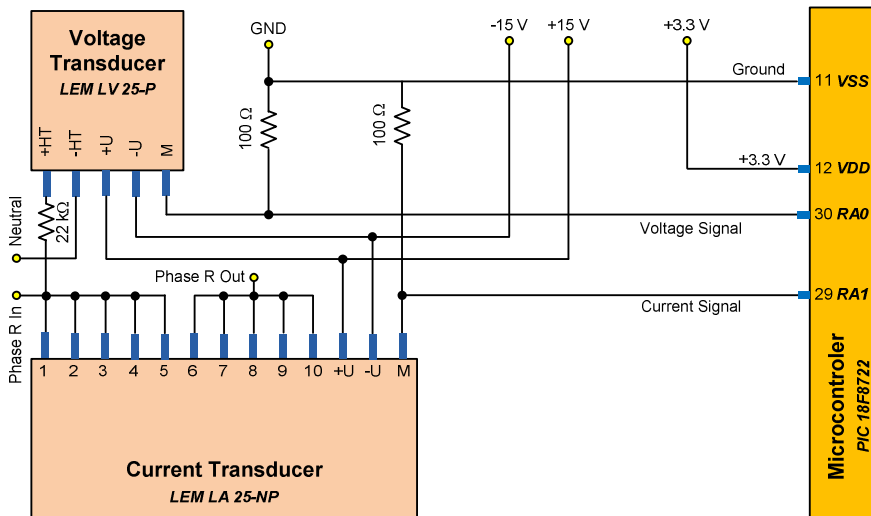

Fig. 3. Electric circuit for the digital AC power measurement solution.

The ADC adds random noise given by n_{ADC1} and n_{ADC2} for the voltage and current channel respectively:

$$\begin{aligned} v_{ADC1}(t) &= VK_V \cos(\omega t + \varphi_V) + n_{ADC1}(t) \\ v_{ADC2}(t) &= IK_I \cos(\omega t + \varphi_I) + n_{ADC2}(t). \end{aligned} \quad (15)$$

Each of these signals is sampled and digitized leading to v_{ADC_1i} and v_{ADC_2i} which are then multiplied numerically leading to:

$$v_{ADC_1i} \times v_{ADC_2i} = \frac{1}{2}VK_VK_I \cos(\varphi_V - \varphi_I) + \frac{1}{2}VK_VK_I \cos(2\Omega i + \varphi_V + \varphi_I) + n_{ADC_1i} \times n_{ADC_2i} + n_{ADC_2i} \times VK_V \cos(\Omega i + \varphi_V) + n_{ADC_1i} \times IK_I \cos(\Omega i + \varphi_I). \quad (16)$$

The power is estimated by taking the average of this vector and dividing by the factor K_VK_I .

$$P = \frac{1}{K_VK_I} \times \frac{1}{M} \sum_{i=1}^M v_{ADC_1}(iT_s) v_{ADC_2}(iT_s), \quad (17)$$

Inserting (16) and considering that the acquisition is done during an integer number of periods, leads to:

$$P = \frac{1}{K_VK_I} \times \left[\frac{1}{2}VK_VK_I \cos(\varphi_V - \varphi_I) + \frac{1}{M} \sum_{i=1}^M n_{ADC_1i} \times n_{ADC_2i} + \frac{VK_V}{M} \sum_{i=1}^M n_{ADC_2i} \cos(\Omega i + \varphi_V) + \frac{IK_I}{M} \sum_{i=1}^M n_{ADC_1i} \cos(\Omega i + \varphi_I) \right]. \quad (18)$$

The expected value of the estimated active power is:

$$E\{P\} = \frac{1}{2}VI \cos(\varphi_V - \varphi_I) = P, \quad (19)$$

which shows that the estimator is unbiased. The variance of the estimator is obtained from (18) considering that the additive noise terms are independent of the signals:

$$VAR\{P\} = \left(\frac{1}{K_VK_I} \right)^2 \times \left[\frac{1}{M^2} VAR \left\{ \sum_{i=1}^M n_{ADC_1i} \times n_{ADC_2i} \right\} + \left(\frac{VK_V}{M} \right)^2 VAR \left\{ \sum_{i=1}^M n_{ADC_2i} \cos(\Omega i + \varphi_V) \right\} + \left(\frac{IK_I}{M} \right)^2 VAR \left\{ \sum_{i=1}^M n_{ADC_1i} \cos(\Omega i + \varphi_I) \right\} \right], \quad (20)$$

The variance of the first summation in (20) is:

$$\begin{aligned} VAR \left\{ \sum_{i=1}^M n_{ADC_1i} \times n_{ADC_2i} \right\} &= E \left\{ \left[\sum_{i=1}^M n_{ADC_1i} \times n_{ADC_2i} \right]^2 \right\} - E^2 \left\{ \sum_{i=1}^M n_{ADC_1i} \times n_{ADC_2i} \right\} = \\ &= \sum_{i=1}^M \sum_{j=1}^M E \{ n_{ADC_1i} \times n_{ADC_2i} \times n_{ADC_1j} \times n_{ADC_2j} \} - \left[\sum_{i=1}^M E \{ n_{ADC_1i} \times n_{ADC_2i} \} \right]^2 = \\ &= \sum_{i=1}^M E \{ n_{ADC_1i}^2 \} E \{ n_{ADC_2i}^2 \} = M \sigma_{n_{ADC_1}}^2 \sigma_{n_{ADC_2}}^2. \end{aligned} \quad (21)$$

Regarding the other two variances, which are equivalent but which relate to different variables, we have, using the definition of variance:

$$VAR \left\{ \sum_{i=1}^M n_i \cos(\Omega i + \varphi) \right\} = E \left\{ \left[\sum_{i=1}^M n_i \cos(\Omega i + \varphi) \right]^2 \right\} - E^2 \left\{ \sum_{i=1}^M n_i \cos(\Omega i + \varphi) \right\}. \quad (22)$$

The expected value of the summation is zero because the noise is considered a null mean random variable:

$$E\left\{\sum_{i=1}^M n_i \cos(\Omega i + \varphi)\right\} = \sum_{i=1}^M E\{n_i\} \cos(\Omega i + \varphi) = 0, \quad (23)$$

The expected value of the square of the summation is given by:

$$\begin{aligned} E\left\{\left[\sum_{i=1}^M n_i \cos(\Omega i + \varphi)\right]^2\right\} &= E\left\{\sum_{i=1}^M \sum_{j=1}^M n_i n_j \cos(\Omega i + \varphi) \cos(\Omega j + \varphi)\right\} = \sum_{i=1}^M \sum_{j=1}^M E\{n_i n_j\} \cos(\Omega i + \varphi) \cos(\Omega j + \varphi) = \\ &= \sum_{i=1}^M E\{n_i^2\} \cos^2(\Omega i + \varphi) = \frac{M}{2} E\{n_i^2\}. \end{aligned} \quad (24)$$

Considering that the noise has a null mean, the expected value of its square is just its variance. We thus have:

$$\text{VAR}\left\{\sum_{i=1}^M n_i \cos(\Omega i + \varphi)\right\} = \frac{M}{2} \sigma_n^2. \quad (25)$$

Inserting (21) and (25) into (20) leads to:

$$\text{VAR}\{P\} = \left(\frac{1}{K_V K_I}\right)^2 \times \left[\frac{1}{M^2} M \sigma_{n_{ADC1}}^2 \sigma_{n_{ADC2}}^2 + \left(\frac{V K_V}{M}\right)^2 \frac{M}{2} \sigma_{n_{ADC2}}^2 + \left(\frac{I K_I}{M}\right)^2 \frac{M}{2} \sigma_{n_{ADC1}}^2 \right]. \quad (26)$$

With some algebraic manipulation we can also write:

$$\text{VAR}\{P\} = \frac{1}{K_V^2 K_I^2 M} \left[\sigma_{n_{ADC1}}^2 \sigma_{n_{ADC2}}^2 + \frac{1}{2} V^2 K_V^2 \sigma_{n_{ADC2}}^2 + \frac{1}{2} I^2 K_I^2 \sigma_{n_{ADC1}}^2 \right]. \quad (27)$$

Finally the standard deviation of the estimated active power is just:

$$\sigma_P = \frac{1}{K_V K_I \sqrt{M}} \sqrt{\sigma_{n_{ADC1}}^2 \sigma_{n_{ADC2}}^2 + \frac{1}{2} V^2 K_V^2 \sigma_{n_{ADC2}}^2 + \frac{1}{2} I^2 K_I^2 \sigma_{n_{ADC1}}^2}. \quad (28)$$

If the noise standard deviation is the same in the two ADC channels (σ_n), one has:

$$\sigma_P = \frac{\sigma_n}{K_V K_I \sqrt{M}} \sqrt{\sigma_n^2 + \frac{1}{2} V^2 K_V^2 + \frac{1}{2} I^2 K_I^2}. \quad (29)$$

Also, if the noise in the channels is much smaller than the input signal at the channels then we have:

$$\sigma_P \approx \frac{\sigma_n}{K_V K_I \sqrt{M}} \sqrt{\frac{1}{2} V^2 K_V^2 + \frac{1}{2} I^2 K_I^2}, \quad \text{for high SNR.} \quad (30)$$

5. Numeric Comparison

For the analog solution the estimated active power standard deviation is given by (14). The noise equivalent bandwidth for a low pass RC filter, is, from [10]:

$$B = \frac{\pi}{2} \frac{1}{2\pi RC}, \quad (31)$$

and η_{lpf} is the spectral density of the voltage noise introduced by the low-pass filter which, in case of a first order RC filter, is given by:

$$\eta_{lpf} = \sqrt{4k_B T R}, \quad (32)$$

where k_B is the Boltzman constant, T is the temperature and R is the resistor value.

In our implementation we chose the values of $R = 300 \text{ k}\Omega$ and $C = 470 \text{ nF}$ to achieve a bandwidth (B) of 1.77 Hz and a DC gain of 1 ($G = 1$). The spectral density of the thermal noise at ambient temperature ($25 \text{ }^\circ\text{C}$) is thus $2.331 \text{ mV}/\sqrt{\text{Hz}}$.

According to the values presented for our implementation, one has, for the 1000 samples acquired:

$$\sigma_P = \frac{1}{4.545 \times 10^{-3} \times 0.1 \times 0.1 \times 1 \times \sqrt{1000}} \times \left[(0.8 \times 10^{-6})^2 \times 1.77 + (2.331 \times 10^{-3})^2 \times 1.77 + (1.861 \times 10^{-3})^2 \right] = 1.295 \text{ W}. \quad (33)$$

We used a 10-bit ADC with a full-scale of 3.3 V. The ideal quantization step is thus:

$$Q = \frac{2FS}{2^{n_b}} = \frac{2 \times 3.3}{2^{10}} = 6.445 \text{ mV}. \quad (34)$$

Here we have considered that the noise introduced by the ADC is only due to the quantization error. Its standard deviation is thus given by:

$$\sigma_n = \frac{Q}{\sqrt{12}} = 1.861 \text{ mV}. \quad (35)$$

In the case of the digital solution the standard deviation of the active power estimation is given by (28). Considering the nominal operating conditions of $V = 325 \text{ V}$ and $I = 3 \text{ A}$ and the rest of the parameters the same as in the analog solution, we have:

$$\sigma_P = \frac{1.861 \times 10^{-3}}{4.545 \times 10^{-3} \times 0.1 \times \sqrt{1000}} \sqrt{(1.861 \times 10^{-3})^2 + \frac{1}{2} 325^2 (4.545 \times 10^{-3})^2 + \frac{1}{2} 3^2 0.1^2} = 0.138 \text{ W}. \quad (36)$$

This value is substantially smaller than the value of 1.295 W obtained with the analog solution. This has to do with the fact that in the analogue solution the product of the voltage and current had to be input into the ADC channel which required it to be scaled, in the multiplier, by a factor K_M which was 0.1 in the presented case. This lowers the signal to noise ratio increasing the measurement uncertainty.

The digital solution, on the other hand, has the disadvantage of seeing the noise from one channel multiplied, in the digital domain, by the signal on the other channel (besides the product of the two signals and the two noises). This increases the variance of the noise proportionally to the square of the signal input into the ADC.

To compare the two solutions solely based on these two factors consider that in the analog solution there is no noise input by the multiplier ($\eta_{multi} = 0$) or by the filter ($\eta_{lpf} = 0$) and that the filter has a DC gain of 1. Equation (14) becomes:

$$\sigma_P = \frac{\sigma_n}{K_V K_I K_M \sqrt{M}}. \quad (37)$$

Consider also that in the digital domain the signal is much higher than the noise and that the signal effective value in the two ADC channels is the same, that is, $V K_V = I K_I = S$. Equation (30) becomes:

$$\sigma_P = \frac{\sigma_n}{K_V K_I \sqrt{M}} S, \tag{38}$$

Equating (37) with (38) one concludes that the precision of the active power estimation is the same for the two solutions, in the special case being considered, if the ADC input signal of the digital solution (S) is the same as the reciprocal of the multiplier scaling factor in the analog solution ($1/K_M$).

It has also the disadvantage of requiring more computational power to carry out the multiplications. The analog solution, on the other end, has the disadvantage of being more expensive and requiring more discrete components (multiplier and filter) which leads to a larger circuit.

6. Conclusions

We analysed, from the point of view of measurement uncertainty, two solutions for AC power measurement: analog and digital. We considered three sources of uncertainty, namely, the noise introduced by the multiplier, the thermal noise introduced by the RC low-pass filter and the additive noise introduced by the ADC. Taking that into account we derived analytical expressions for the standard deviation of the active power estimation using both methods. These expressions, by themselves, can be used, for instance, to compute the minimum number of samples that should be acquired in order to limit the measurement uncertainty to a given bound.

Comparing the two measurement solutions one can conclude that both have advantages and disadvantages as listed in Table 1 and Table 2.

Table 1. Advantages and disadvantages of the analog solution.

Advantages	Disadvantages
Less computational power required	More area required for the circuit
	Noise introduced by the analog multiplier
	Noise introduced by the low-pass filter
	Signal scaled down before going into the ADC which degrades the signal-to-noise ratio

Table 2. Advantages and disadvantages of the digital solution.

Advantages	Disadvantages
Less area required for the circuit	More computational power required
More flexible in terms of software algorithm used to estimate power	Noise digitally multiplied by the signal which increases its variance
	Two ADC channels required

Furthermore, we presented the actual electronic circuits for the AC power measurement and with real figures computed the precision of both measurement methods. The conclusion was that, for the conditions of the application at hand (data logging in a Vodafone radio communication base station), the digital solution has a better precision.

All in all we conclude that the digital solution is more flexible allows for a smaller implementation area and can have a better estimation precision.

Acknowledgements

This work was sponsored by Vodafone Portugal and the research project “In ADC – Detailed Study of Analogue to Digital Converters Characterization Methods”, PTDC/EEA ELC/68843/2006 (FCT).

References

- [1] U. Pogliano, B. Trinchera: “RMS Voltage Measuring System for Precise Evaluation of Electric Quantities”. *Metrol. Meas. Syst.*, vol. XIV, no. 4, 2007, pp. 555–562.
- [2] B. D’apice, C. Landi, A. Pelvio, N. Rignano: “A Multi-DSP Based Instrument for Real-Time Energy and PQ Measurements”. *Metrology and Measurement Systems*, Vol. XIV, no. 4, 2007, pp. 495-506.
- [3] M. Szmajda, K. Górecki, J. Mroczka, J. Borkowski: “Antialiasing Filters in Power Quality Digital Measurement Systems”. *Metrol. Meas. Syst.*, vol. XII, no. 4, 2005, pp. 355–370.
- [4] F. Travassos, F. Corrêa Alegria: “Automatic Monitoring of a Vodafone Radiocommunication Base Station”. *International Conference of Electrical and Electronics Engineering*, London, United Kingdom, July 2–4, 2008, pp. 342–347.
- [5] PIC18F8722 Family Data Sheet, Microchip, 2004.
- [6] Ch.K. Alexander: *Fundamentals of Electric Circuits*. McGraw-Hill, 2005.
- [7] Voltage Transducer LV 25-P Specification Sheet, LEM.
- [8] Current Transducer LA 25-NP Specification Sheet, LEM.
- [9] AD633 Data Sheet, Analog Devices, revision E, 2002.
- [10] T.J. Sobering: “Equivalent Noise Bandwidth”. *SDE Consulting, Technote 1*, June 2008.